

.....

FA130CP **Security System**

Installation and Set-Up Guide

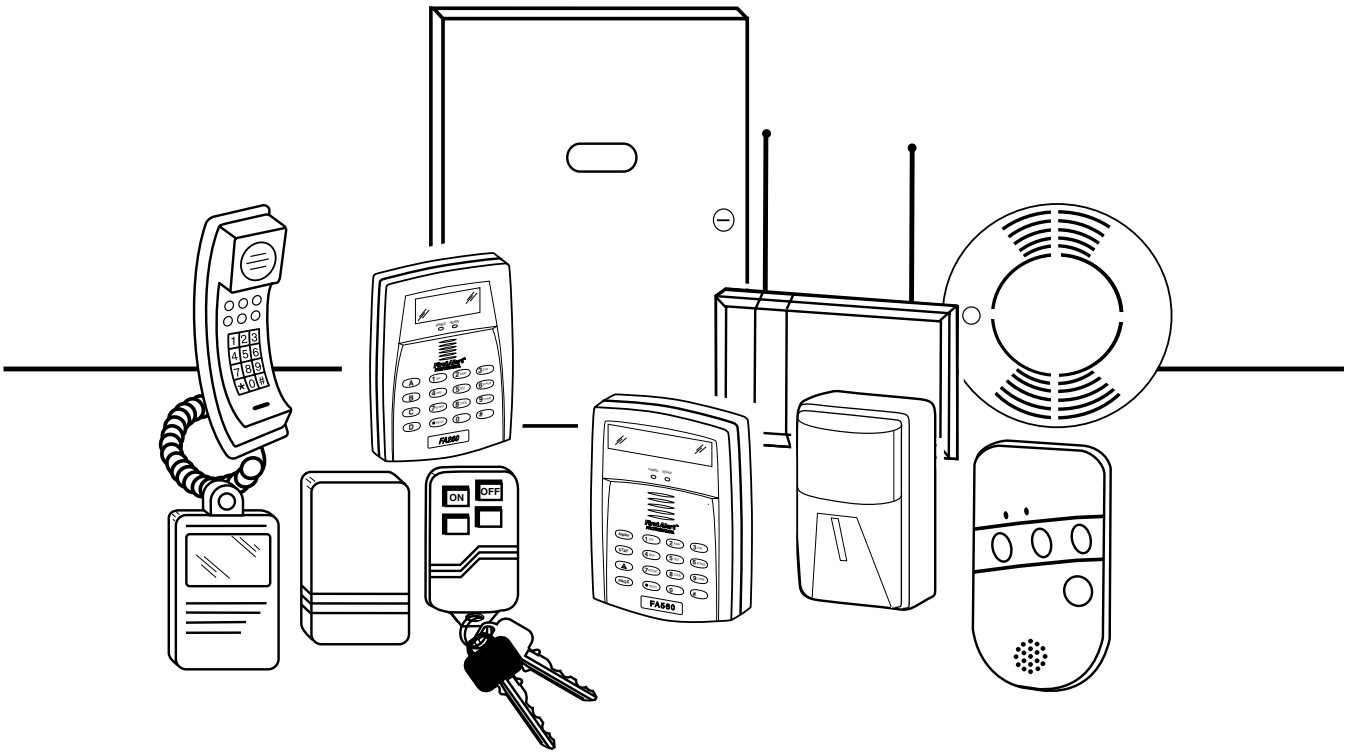

RECOMMENDATIONS FOR PROPER PROTECTION

The Following Recommendations for the Location of Fire and Burglary Detection Devices Help Provide Proper Coverage for the Protected Premises.

Recommendations For Smoke And Heat Detectors

With regard to the number and placement of smoke/heat detectors, we subscribe to the recommendations contained in the National Fire Protection Association's (NFPA) Standard #72 noted below.

Early warning fire detection is best achieved by the installation of fire detection equipment in all rooms and areas of the household as follows: For minimum protection a smoke detector should be installed outside of each separate sleeping area, and on each additional floor of a multi-floor family living unit, including basements. *The installation of smoke detectors in kitchens, attics (finished or unfinished), or in garages is not normally recommended.*

For additional protection the NFPA recommends that you install heat or smoke detectors in the living room, dining room, bedroom(s), kitchen, hallway(s), attic, furnace room, utility and storage rooms, basements and attached garages.

In addition, we recommend the following:

- Install a smoke detector inside every bedroom where a smoker sleeps.
- Install a smoke detector inside every bedroom where someone sleeps with the door partly or completely closed. Smoke could be blocked by the closed door. Also, an alarm in the hallway outside may not wake up the sleeper if the door is closed.
 - Install a smoke detector inside bedrooms where electrical appliances (such as portable heaters, air conditioners or humidifiers) are used.
- Install a smoke detector at both ends of a hallway if the hallway is more than 40 feet (12 meters) long.
- Install smoke detectors in any room where an alarm control is located, or in any room where alarm control connections to an AC source or phone lines are made. If detectors are not so located, a fire within the room could prevent the control from reporting a fire or an intrusion.

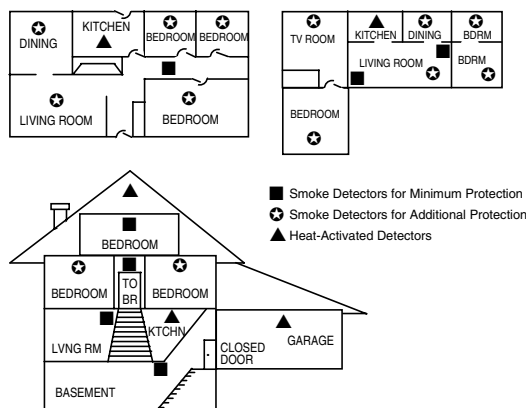

THIS CONTROL COMPLIES WITH NFPA REQUIREMENTS FOR TEMPORAL PULSE SOUNDING OF FIRE NOTIFICATION APPLIANCES.

Recommendations For Proper Intrusion Protection

For proper intrusion coverage, sensors should be located at every possible point of entry to a home or commercial premises. This would include any skylights that may be present, and the upper windows in a multi-level building.

In addition, we recommend that radio backup be used in a security system so that alarm signals can still be sent to the alarm monitoring station in the event that the telephone lines are out of order (alarm signals are normally sent over the phone lines, if connected to an alarm monitoring station).

Table Of Contents

.....

Features and Installation Highlights	1-1
Capabilities	1-1
Functions.....	1-1
Compatible Devices	1-1
Important Installation Highlights (Installer Please Read).....	1-2
Mounting and Wiring the Control	2-1
Cabinet and Lock.....	2-1
Mounting the PC Board Alone (no RF Receiver)	2-1
Mounting Board with RF Receiver	2-2
Wiring to Keypads	2-3
Sounder (Bell) Connections.....	2-4
Wiring the AC Transformer	2-4
Backup Battery	2-4
Earth Ground.....	2-5
Hardwire Zones.....	2-6
Smoke Detectors	2-6
Installing the RF Receiver	2-7
Installing a 5800™ Module.....	2-7
Installing the Transmitters.....	2-8
Installing a Keypad.....	2-8
Connecting Relay Modules.....	2-9
On-Board Triggers.....	2-10
Phone Line/Phone Module Connections.....	2-10
Long Range Radio Connections	2-11
AAV Connections	2-12
Programming Overview	3-1
About Programming	3-1
Keypads.....	3-1
Wireless Receiver and Transmitters	3-2
Pager Programming	3-2
Function Keys	3-2
Output Devices	3-2
Zone Type Definitions	3-3
Mechanics of Programming.....	3-5
Data Field Programming	4-1
About Data Field Programming	4-1
Programming Data Fields.....	4-1
System Setup Fields	4-1
Zone Sounds & Timing.....	4-2
Dialer Programming.....	4-3
System Status Report Codes.....	4-4
Miscellaneous System Fields	4-6
Pager Programming Fields	4-8
Miscellaneous System Fields	4-8
Configurable Zone Type Programming Fields.....	4-9
Keypad Programming Fields	4-11

Table Of Contents

Menu Mode Programming	5-1
Zone Programming Overview (*56 and *58 Menu Modes)	5-1
*56 Zone Programming Procedure	5-1
*58 Expert Programming Mode Procedures	5-3
Wireless Key Programming Templates	5-4
Output Device Programming Overview (*79/*80 Menu Mode)	5-6
*79 Menu Mode: Output Device Mapping.....	5-6
*80 Menu Mode: Defining Output Functions	5-7
Zone List Overview (*81 Menu Mode).....	5-9
Zone List Programming.....	5-9
Function Key Programming Overview (*57 Menu Mode).....	5-10
Programming Function Keys	5-10
About Descriptor Programming Overview (*82 Menu Mode).....	5-11
Programming Zone Descriptors (Menu mode *82)	5-11
Adding Custom Words.....	5-12
Programming Installer and User Schedules.....	5-14
System Communication and Operation	6-1
System Communication Overview.....	6-1
Report Code Formats.....	6-1
Ademco Contact ID®	6-3
User Security Codes	6-4
Keypad Functions.....	6-4
Various System Trouble Displays.....	6-6
Testing the System	7-1
About Test Procedures	7-1
System Test.....	7-1
Checking Transmitter Enrollment (Sniffer Mode)	7-1
Go/No Go Test Mode	7-2
Dialer Communication Test	7-2
Automatic Standby Battery Tests	7-2
Specifications & Accessories	8-1
Security Control.....	8-1
Compatible Devices	8-1
5800 Series Transmitter Input Loop Identification	8-2
Regulatory Agency Statements	9-1
Limitations and Warranty	10-1

Features and Installation Highlights

This system is a SIA-compliant control (in accordance with ANSI/SIA standard CP-01-2000 control unit standard-features for false alarm reduction).

Capabilities

- Up to 22 zones plus 8 keyfob zones (zones 49-56) for total of 30 zones:
 - 6 basic hardwired zones (zone 1-6)
 - Supports up to 16 wireless transmitter zones (5800 series; zones 9-24)
 - Supports 1 configurable zone type
- Up to 16 security codes, each with separate authority levels
- Supports Downloading: Via an IBM compatible computer, Compass downloading software, and a compatible HAYES or CIA modem specified by Ademco.

Functions

- Single-button arming feature: Can use dedicated keys to arm the system AWAY or STAY
- Up to 2 schedules (1 installer, 1 end-user), to control devices and/or auto-arm/disarm the system
- One keypad macro, which can simplify a long command string (e.g., bypassing zones before arming)
- Paging feature allows certain system conditions to be reported to one pager phone number; can use a dedicated key on keypads to send a signal to the pager
- Event Logging records up to 32 selected events in a history log; control and readout from the log is done via Ademco Compass Downloader software or installer/master code at Keypad
- Zone descriptors for all zones (useful only when using Alpha display keypads and/or the FA4285/FA4286 Phone Module).
- Optional bell supervision detects external sounder wiring short or open; causes a trouble condition, keypad display, and sends a report to the central monitoring station, if enabled.
- Optional RF jam detection for wireless systems detects a condition that may impede proper RF reception (i.e., jamming or other RF interference); causes keypad display, and sends a report to the central monitoring station (if trouble reporting is enabled).

Compatible Devices

- Supports up to 8 Addressable Keypads: FA215KP/FA260KP Fixed-Word Display Keypads, FA560KP Alpha Keypad, FA560VKP Alpha Display Voice Keypad, FA260RF Keypad/Transceiver
- Supports 5881 series receiver and 5800 series transmitters
- Up to 4 output relays (4204) plus two on-board triggers (does not support Powerline Carrier Devices) -- Up to 12 output functions
- Ademco FA4285/FA4286 Phone Module; provides access to the system via on premises or off-premises phones for arming, disarming, etc., plus control of relay outputs.
- Audio Alarm Verification (using AAV module, such as ADEMCO's UVCN module); can be used in conjunction with an output trigger to permit voice dialog between an operator at the central station and a person at the premises.
- Alarm output provides a 12VDC, 2 AMP output that can drive the compatible sounders; steady output for burglary/panic, or temporal pulse (3 pulses – pause – 3 pulses – pause – 3 pulses. . .) for fire. Uses current limiting circuitry for protection.
- Auxiliary Power Output: 12VDC, 600 mA maximum (uses PTC for protection).
- Backup Battery: Rechargeable (sealed lead-acid type) 12VDC, 4AH minimum.
- Long Range Radio: Primary telephone number messages can be reported via ECP connection to various Long Range Radios (check compatibility and availability of specific models)
- AC Power Supply: Plug-in 120VAC transformer, ADEMCO 1321

NOTE: All devices and accessories used in a Canadian installation must be Listed for use in Canada.

Important Installation Highlights (Installer Please Read)

- This system uses addressable keypads and Relay Modules (see table of addresses in *Programming Overview* section).
- Keypads must be set for addresses 16-23 (first keypad is address 16, which is different from previous controls) and programmed in data fields *190-*196.
- 4204 Relay Modules must be set for specific address 12 (see *Connecting Relay Modules* section).
- Relays have two programming menu modes: Use *79 Menu mode to map module addresses and device (output) numbers. Use *80 Menu mode to define the output functions (see *Output Device Programming* section).
- This system supports programmable function keys. Use *57 Menu mode to define the function keys (see *Function Key Programming* section).
- This system provides various paging features. Refer to the *Programming Overview* section for a summary on pager programming.

Mounting and Wiring the Control

Cabinet and Lock

1. Mount the control cabinet to a sturdy wall in a clean, dry area, which is not readily accessible to the general public, using fasteners or anchors (not supplied) with the four cabinet mounting holes.
2. Remove cabinet door, then remove the lock knockout from the door. Insert the key into the lock.
3. Position the lock in the hole, making certain that the latch will make contact with the latch bracket when the door is closed. When correctly positioned, push the lock until it is held securely by its snap tabs.

NOTES

- The cabinet can be closed and secured without a lock by using 2 screws in the cover's edge.

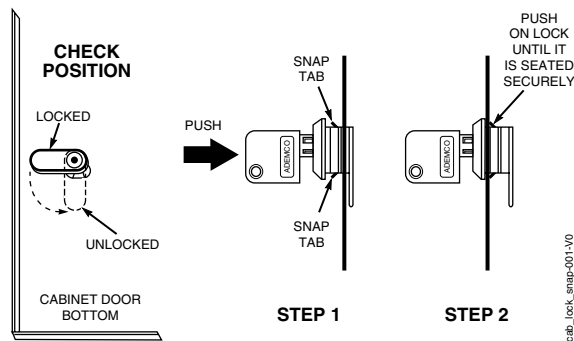

Figure 1. Installing the Cabinet Lock

Mounting the PC Board Alone (no RF Receiver)

1. Hang two short mounting clips (provided) on the raised cabinet tabs (see Detail B in Fig. 2).
2. a. Insert the top of the circuit board into the slots at the top of the cabinet. Make sure that the board rests on the correct row (see Detail A).
- b. Swing the base of the board into the mounting clips and secure the board to the cabinet with the accompanying screws (see Detail B).

NOTES

- Before installing the cabinet's contents, remove the metal cabinet knockouts required for wiring entry. Do not remove the knockouts after the circuit board has been installed.

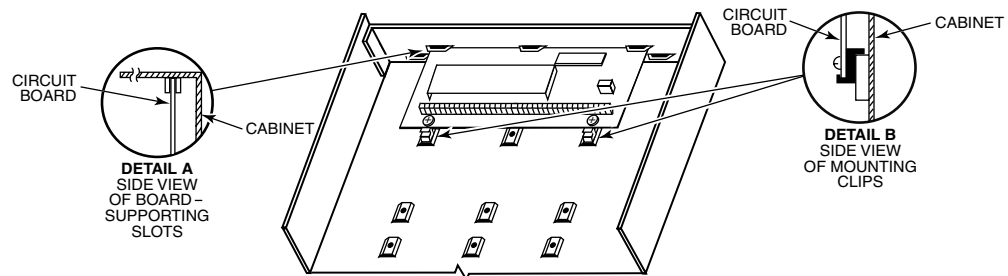

Figure 2. Mounting the PC Board

Mounting Board with RF Receiver

1. a. Remove the receiver board from its case, then insert the top of the board into the slots at the top of the cabinet, as shown in Detail A in Figure 3. Make sure that the board rests on the correct row of tabs.
 - b. Swing the base of the board into the mounting clips and secure it to the cabinet with the accompanying screws.
 - c. Insert the top of the control's board into the slot in the clips and position two clips at the lower edge of the board.
 - d. Swing this board into place and secure it with two additional screws.
2. Insert grounding lugs (supplied with the receiver) through the top of the cabinet into the left-hand terminals of the antenna blocks (at the upper edge of the receiver board) and secure them to the cabinet top with the screws provided, as shown in Detail B.
3. Insert the receiver's antennas through the top of the cabinet, into the blocks' right-hand terminals, and tighten the screws.

NOTES

- Do not mount the cabinet on or near metal objects. This will decrease RF range and/or block RF transmissions from wireless transmitters.
- Do not locate the cabinet in an area of high RF interference (revealed by frequent or prolonged lighting of the LED in the receiver after it is operational (random flicker is OK))

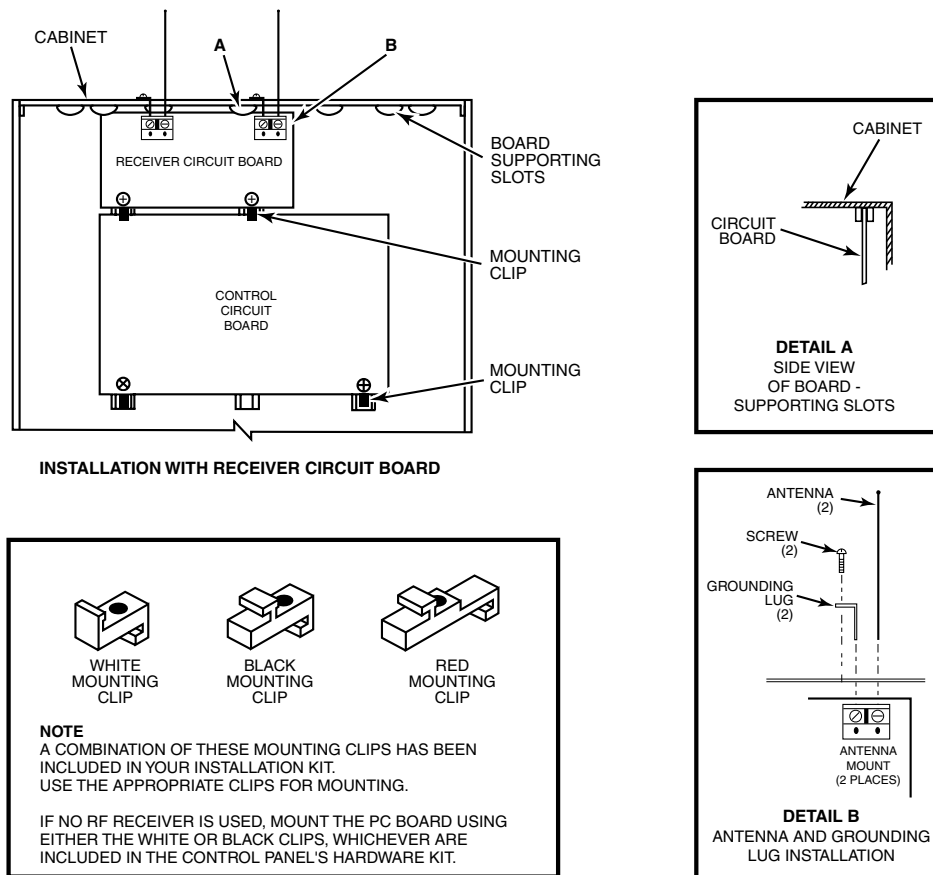

pc_mount-001-V1

Figure 3. Mounting the PC Board and RF Receiver

Wiring to Keypads

1. Connect keypads to the keypad terminals as shown on the Summary of Connections diagram. Determine wire gauge using the Wiring Run Chart below.
2. Set keypad addresses. Refer to the address setting instructions included with the keypads and set each keypad device address according to the chart at right.
3. Program the keypad addresses and sound options in data fields *190-*196.
IMPORTANT: Each keypad must be assigned a unique address, **starting at address 16**. Keypads programmed with the same address will give unpredictable results.

Supplementary Power (optional)

1. Connect as shown. Be sure to connect the negative (-) terminal on the power supply unit to terminal 4 (AUX -) on the control.

NOTES

- Typical Fixed-Word Display: FA215KP/FA260KP
- Typical Alpha Display: FA560KP
- Voice Keypad: FA560VKP
- The system supports up to 8 keypads (see program fields *190-*196).
- For single 4-wire runs, determine the current drawn by all units, then refer to the Wiring Run chart to determine the maximum length that can be safely used for each wire size.
- Use supplementary power if the control's aux. power load for all devices exceeds 600mA. Suggested power supply: AD12612

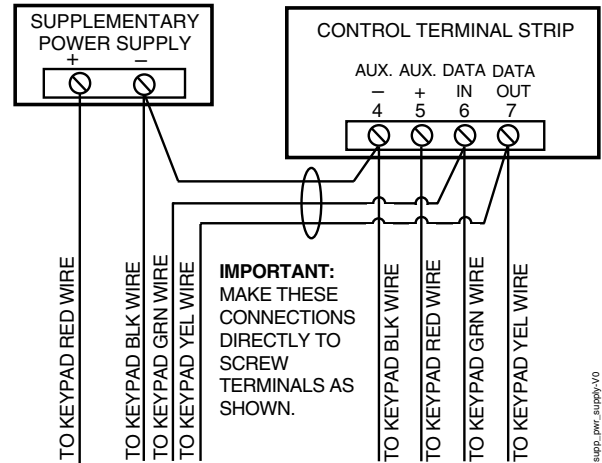

Figure 4. Using a Supplementary Power Supply

Keypad Addresses

Keypad	Address	Keypad	Address
no. 1	16**	no. 5	20
no. 2	17	no. 6	21
no. 3	18	no. 7	22
no. 4	19	no. 8	23

** The **first keypad is address 16**, which is always enabled and set with all sounds on.

UL Use a UL Listed, battery-backed supply for UL installations. The battery supplies power to these keypads in case of AC power loss. The battery-backed power supply should have enough power to supply the keypads with the UL required minimum standby power time.

Keypads powered from supplies that do not have a backup battery will not function if AC power is lost. Make sure to power at least one keypad from the control's auxiliary power output.

Wire Size	TOTAL CURRENT DRAWN BY ALL DEVICES CONNECTED TO A SINGLE WIRE RUN				
	50 mA or less	100 mA	300 mA	500 mA	600 mA
#22	500 ft (152m)	250 ft (76m)	80 ft (24m)	50 ft (15m)	42 ft (13m)
#20	750 ft (228.6m)	380 ft (116m)	130 ft (39.6m)	80 ft (24m)	67 ft (20.4m)
#18	1300 ft (396m)	650 ft (198m)	220 ft (67m)	130 ft (39.6m)	115 ft (35m)
#16	1500 ft (457m)	1000 ft (305m)	330 ft (100.5m)	200 ft (70m)	170 ft (52m)

* Includes Keypads, RF Receivers, Zone Expander/Relay Units, or FA4285/FA4286 Phone Module. Maximum wire lengths for any device that is homerun to the control can also be determined from the Wiring Run Chart, based on the current draw of that device alone. The length of all wire runs combined must not exceed 1500 feet (457m) when unshielded quad conductor cable is used (750 feet if shielded cable is used). This restriction is due to the capacitive effect on the data lines when quad cable is used.

Sounder (Bell) Connections

1. Make sounder connections to alarm output terminals 3 (+) and 4 (-).
For supervised output, continue with steps 2 and 3.
2. Cut the red Bell Supervision Jumper located above terminals 2 and 3 on the control board.
3. Connect a 2k ohm resistor across the terminals of the last sounder.

This control complies with NFPA requirements for temporal pulse sounding of fire notification appliances. Temporal pulse sounding for a fire alarm consists of:
3 pulses – pause – 3 pulses – pause – 3 pulses–etc..

NOTES

- The 12VDC sounder output activates when an alarm occurs.
- Total current drawn from this output cannot exceed 2 amps (going beyond 2 amps will overload the power supply, or may cause the electronic circuit protecting the sounder output to trip).
- You must install a battery, since the battery supplies this current.

UL

- Use only UL Listed sounding devices for UL installations.
- Bell supervision is required for fire alarm installations.
- The total current drawn from the alarm output and the auxiliary power output, combined, cannot exceed 600 mA. In addition, the sounding device must be a UL Listed audible signal appliance rated to operate in a 10.2-13.8 VDC voltage range, and must be mounted indoors.

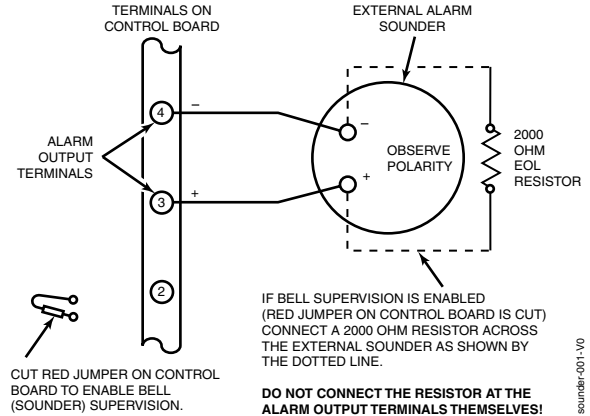

Figure 5. Sounder Wiring (Supervised)

Wiring the AC Transformer

Connect the 1321 Transformer to terminals 1 and 2 on the control board. See wiring table for wire gauge to use. (Use 1321CN in Canada.)

Wiring Table

Distance from control	Wire Gauge
Up to 50 feet	# 20
50–100 feet	# 18
100-250 feet	# 16

NOTES

- Use caution when wiring the transformer to the control to guard against blowing the transformer fuse (the fuse is non-replaceable).
- Wiring to the AC transformer must not exceed 250 feet using 16 gauge wire. The voltage reading between terminals 1 and 2 of the control must not fall below 16.5VAC or an “AC LOSS” message will be displayed.
- Do not plug the transformer into the AC outlet while making any wiring connections to the control. As a safety precaution, always power down the control when making such connections.

Backup Battery

1. Place the 12-volt backup battery in the cabinet.
2. After all connections to the control are completed and AC power has been applied, connect the red and black flying leads on the control board to the battery. Do not attach these leads to the battery terminals until all connections are completed.

IMPORTANT: The panel will not power up initially on battery power only. You must plug the transformer in first, and then connect the battery.

UL For UL installations and Residential fire installations, refer to the chart below for the correct battery size required to meet the mandatory standby time.

**CALIFORNIA STATE FIRE MARSHALL (CSFM) AND UL RESIDENTIAL FIRE
24-HOUR BATTERY BACKUP REQUIREMENTS**

The California State Fire Marshal and UL have regulations which require that all residential fire alarm control panels must be provided with a backup battery which has sufficient capacity to operate the panel and its attached peripheral devices for 24 hours in the intended standby condition, followed by at least 4 minutes in the intended fire alarm signaling condition. This control panel can meet these requirements without using a supplementary power supply, provided that the panel's auxiliary power and bell output currents are limited as indicated below.

OUTPUT LIMITATIONS TO MEET CSFM 24 HOUR BATTERY BACKUP REQUIREMENTS AND UL RESIDENTIAL FIRE INSTALLATIONS			
OUTPUT CURRENT LIMITATIONS		BATTERY INFORMATION	
Output Current Total	Maximum Auxiliary Current	Battery Capacity To Use (Amp/Hrs)	Recommended Battery (Yuasa Model No.)
600mA maximum total of auxiliary power plus bell output currents	45mA	4AH	NP4-12 (or ADEMCO 467)
	160mA	7AH	NP7-12
	200mA	8AH	NP4-12 (two) ‡
	425mA	14AH	NP4-12 (two) ‡
	500mA	17.2AH	NPG18-12

‡ **NOTE:** Use two batteries, connected in parallel. Obtain an Ademco Battery Harness Kit SA5140-1. (Both batteries will fit inside the panel's cabinet.)

Earth Ground

Metal Cold Water Pipe:

Use a non-corrosive metal strap (copper is recommended) firmly secured to the pipe to which the ground lead is electrically connected and secured.

AC Power Outlet Ground:

Available from 3-prong, 120VAC power outlets only. To test the integrity of the ground terminal, use a 3-wire circuit tester with neon lamp indicators, such as the UL Listed Ideal Model 61-035, or equivalent, available at most electrical supply stores.

- This product has been designed and laboratory-tested to ensure its resistance to damage from generally expected levels of lightning and electrical discharge, and does not normally require an earth ground.
- If an earth ground is desired for additional protection in areas of severe electrical activity, terminal 25 on the control board, or the cabinet, may be used as the ground connection point. The examples of good earth grounds listed at the left are available at most installations.

AUXILIARY DEVICE CURRENT DRAW WORKSHEET

* If using hardwire devices such as PIRs, refer to the specifications for that particular unit's current draw.

‡ Figures are for relays OFF/relays ON.

DEVICE	CURRENT	UNITS	TOTAL CURRENT
FA215KP Fixed-Word Keypad	35mA		
FA260KP Fixed-Word Keypad	75mA		
FA560KP Alpha Keypad	80mA		
FA260RF Keypad/Transceiver	105mA		
FA560VKP Voice Keypad	60mA standby/190mA alarm		
5881/5882 RF Receiver	35mA		
4204 Relay Unit	15/180mA‡		
FA4285 Phone Module	160mA		
FA4286 Phone Module	300mA		
*			
*			
*			

(Current available from Aux. terminals = 600 mA max.)†

TOTAL =

† In UL installations, maximum current draw from the Auxiliary Output and the Alarm Output **combined** must not exceed 600 mA (500 mA max from Auxiliary Output).

Hardwire Zones

Normally Open Zones/ Normally Open EOLR Zones

1. Connect open circuit devices in parallel across the loop; for EOLR zones, connect the EOLR across the loop wires at the last device.
2. Enable normally open/EOLR zones using Zone Programming mode, “Hardwire Type” prompt.

Normally Closed Zones/Normally Closed EOLR Zones

1. Connect closed circuit devices in series in the high (+) side of the loop; for EOLR zones, connect the EOLR in series following the last device.
2. Enable normally closed/EOLR zones using Zone Programming mode, “Hardwire Type” prompt.

NOTES

- **EOLR:** If the EOLR is not at the end of the loop, the zone is not properly supervised and the system may not respond to an “open” on the zone.

UL For UL commercial burglar alarm installations, use normally closed zones.

Smoke Detectors

4-Wire Smoke Detectors

Connect 4-wire smoke detectors to any zone as shown below. This control does not automatically reset power to 4-wire smoke detector zones, so you must use a relay (e.g., 4204), or on-board trigger to reset power (also required for fire verification). Do this by programming the designated relay/trigger as zone type 54 (fire zone reset); see On-Board Trigger section for other information.

Figure 7. 4-Wire Smoke Detector Connections

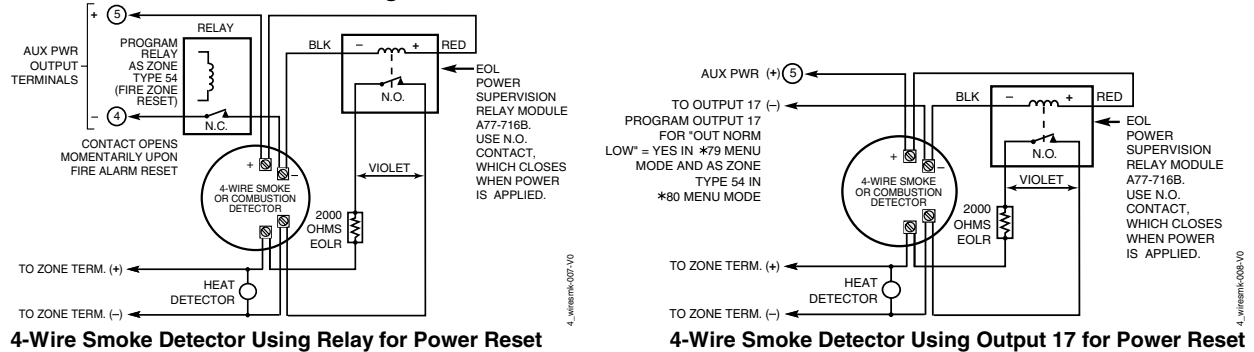

NOTES

- **Fire Verification (zone type 16):** The control panel will “verify” a fire alarm by resetting the smoke detectors after the first alarm trigger, and then waiting 90 seconds for a second alarm trigger. If the smoke detector or thermostat does not trigger again, the control will disregard the first trigger, and no alarm signal will occur. This feature eliminates false alarms due to electrical or physical transients.

SIA Installations: If using fire verification on zones other than zone 1, UL Fire Alarm Listed relay accessories must be used to reset power as described above.

Installing the RF Receiver

You can use one of the following receivers:

RF Receiver	No. of Zones
5881L/5882L	up to 8
5881M/5882M	up to 16 (transmitter zone numbers = 9-24; button zone numbers = 49-56)
5883, FA260RF	up to 16 (transmitter zone numbers = 9-24; button zone numbers = 49-56)

1. Set Device Address to “00” as described in its instructions (set all switches to the right, “off” position).
2. Mount the receiver, noting that the RF receiver can detect signals from transmitters within a nominal range of 200 feet.
3. Connect the receiver's wire harness to the control's keypad terminals. Plug the connector at the other end of the harness into the receiver. Refer to the installation instructions provided with the receiver for further installation procedures regarding antenna mounting, etc.

NOTES

- The receiver is supervised and a trouble report is sent (“CHECK 100” displayed) if communication between the panel and receiver is interrupted, or if no valid RF signals from at least one supervised transmitter are received within 12 hours.

If the receiver is mounted remotely:

- Place the RF receiver in a high, centrally located area for best reception.
- Do not locate the receiver or transmitters on or near metal objects. This will decrease range and/or block transmissions.
- Do not locate the RF receiver in an area of high RF interference (indicated by frequent or prolonged lighting of the LED in the receiver; random flicker is OK).
- Do not locate RF receiver closer than 10 feet from any keypads to avoid interference from the microprocessors in those units.

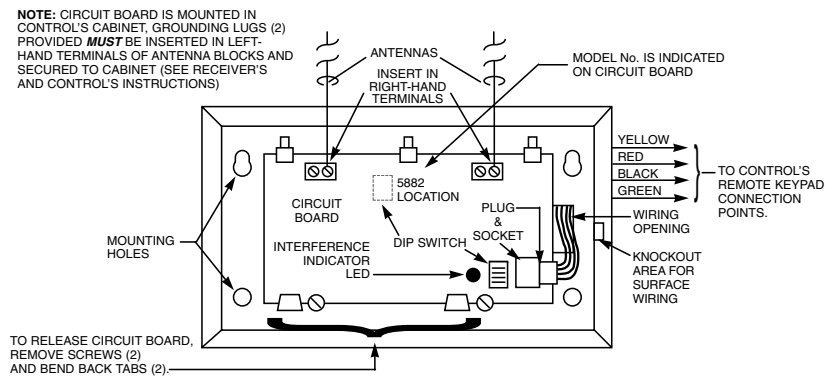

Figure 9. 5881/5882 RF Receiver (cover removed)

Installing a 5800TM Module

1. Mount the 5800TM next to the RF receiver (between one and two feet from the receiver's antennas) using its accompanying mounting bracket. Do not install within the control cabinet.
2. Connect the 5800TM to the control panel's keypad connection terminals as shown on the Summary of Connections diagram and set to address 28.

NOTES

- Use this module only if you are using one or more wireless bi-directional keypads or keyfobs with a wireless Receiver; 5800TM is not necessary if using a Transceiver (e.g., 5883).
- The 5800TM must be set to address 28 (cut red-W1 jumper).
- For additional information regarding the 5800TM, refer to the 5800TM's instructions.

Installing the Transmitters

1. To be sure reception of the transmitter's signal at the proposed mounting location is adequate, perform a Go/No Go Test, described in the **Testing the System** section.
2. Install transmitters in accordance with the instructions provided with each.
3. Set 5827, 5827BD, 5804BD wireless keypads to the programmed House ID (field *24), using its DIP switches (5827) or follow the instructions provided with the device.

ULC NOTE: In accordance with ULC standards, the RF supervision period for the FA130CP is three hours for Fire zones (Zone Type 9 and 16) and 12 hours for all other zone types.

NOTES

- Refer to the table of compatible devices at the back of this manual.
 - Supervised transmitters[†] send check-in signals to the receiver at 70-90 minute intervals. If at least one check-in message is not received from each transmitter within a 12-hour period, the “missing” transmitter number(s) and “CHECK” is displayed.
- [†] Hand-held transmitters (e.g., 5802, 5802CP, 5804, 5804BD, 5827, 5827BD) do not send check-in signals.

UL The following transmitters are not intended for use in UL installations: 5802MN, 5802MN2, 5804, 5804BD, 5814, 5816TEMP, 5819, 5819WHS & BRS, and 5850.

The 5827BD and 5800TM can be used in UL Listed Residential Burglar installations.

Transmitter Battery Life

- See Wireless Transmitter paragraph in the *Limitations of This Alarm System* statement located at the end of this manual for information on transmitter battery life.
- Some transmitters (e.g., 5802 and 5802CP) contain long-life but non-replaceable batteries, and no battery installation is required. At the end of their life, the complete unit must be replaced (and a new serial number enrolled by the control).
- Button-type transmitters (such as 5801, 5802, and 5802CP) should be periodically tested for battery life.
- The 5802MN and 5804 Button Transmitters have replaceable batteries.

Do not install batteries in wireless transmitters until you are ready to enroll during system programming. After enrolling, batteries need not be removed.

Installing a Keyswitch

1. Connect the 4146 keyswitch's normally open momentary switch to a zone's terminals. Remove the 2000 ohm EOL resistor if connected across the selected zone.
2. Using a standard keypad cable as shown:
Connect the yellow and white keyswitch wires to trigger connector pin 3 (+12V).
Connect the Red and Green LED wires to the appropriate output 17/output 18 trigger connector pins.
3. Connect a 2000 ohm EOL resistor across the momentary switch.
4. You can wire an optional closed-circuit tamper switch (model 112) in series with the zone. If the switchplate is then removed from the wall, the tamper will open, disabling keyswitch operation until the system is next disarmed from the keypad.
If the tamper is opened when the system is armed, an alarm will occur.

NOTES

- When using a keyswitch, the zone it is connected to is no longer available for use as a protective zone.
- Use *56 Menu mode to program the keyswitch zone and assign it zone type 77.
- Use *80 Menu mode to program the LED functions: program outputs 17 and 18 for system operation zone type 78 (red LED) and 79 (green LED) as appropriate (see **Output Device Programming** section).

UL A UL Listed keyswitch is required for fire installations and UL commercial and residential burglar alarm installations.

If a keyswitch is used on:

- an installation that transmits opening and closing signals, the keyswitch zone must be programmed to send opening and closing signals.
- a UL commercial burglar alarm installation, the keyswitch's tamper switch must be connected in to the alarm system. This tamper switch zone must also be programmed for Zone Type 05 – Trouble by Day / Alarm by Night.
- a fire alarm installation, the keyswitch must be located next to an alphanumeric display keypad.

The Ademco 4146 keyswitch is UL Listed.

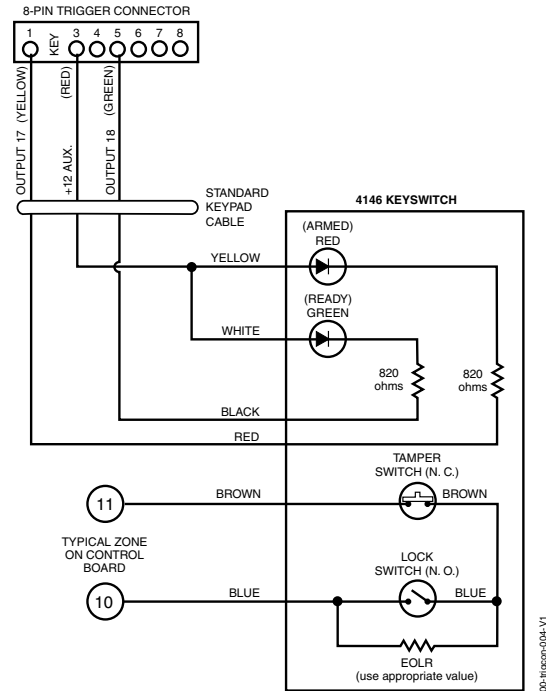

Figure 10. Keyswitch Wiring Connections

Connecting Relay Modules

1. Mount either remotely or in the control panel.
2. Connect to control's keypad terminals using the connector harness supplied with the module. Use standard 4-conductor twisted cable for long wiring runs.
3. Set the module's device address to address 12.
4. Connect the desired field wiring to the unit's relay contact terminals.

NOTES

- Use 4204 module.
- Supervision: 4204 module is supervised against removal. The module's device address is displayed as follows if a module is disconnected from the control's terminals, or if the module cover is removed and the tamper jumper is installed:
Alpha: CHECK xx Wire Expansion
FAULT xx Wire Expansion
ALARM xx Wire Expansion
Fixed-Glass: lxx (or 91 if field *199 set for 2-digit display); where "xx" is the module's address.
- If communication/tamper failure occurs on a device with zones wired to it, all zones on the device will be displayed.

UL For UL installation requirements, refer to the Installation Instructions for the 4204.

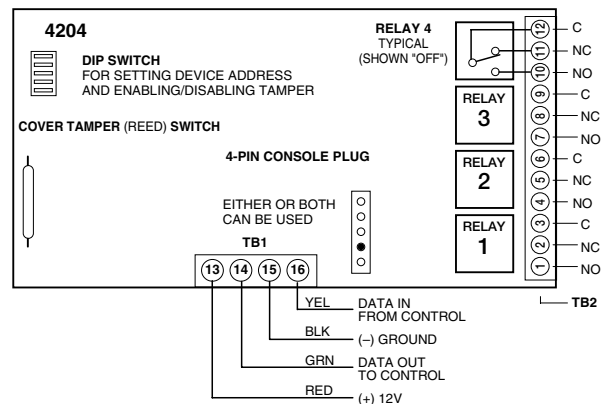

Figure 11. 4204 Connections to Control

On-Board Triggers

Connect field wiring to the desired trigger pin on the 8-pin trigger connector centrally located above the terminal strip.

You can use a standard keypad cable as shown.

UL If on-board triggers are used, the wiring between the control unit and the UL Listed device must be run in conduit, be no more than 3 feet apart and have no intervening barriers or walls.

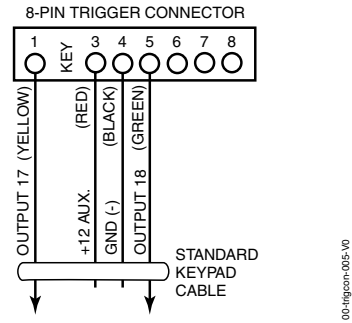

Figure 12.
On-Board Trigger Connector with Standard Keypad Cable

NOTES

- There are two on-board triggers that can be used to activate output devices.
- These outputs are normally high, and go low upon programmed condition.
- Outputs can be programmed for inverted operation (normally low, go high) using *79 Menu mode.
- Program these triggers using *80/*81 Menu modes as you would for any other relay output.
- When using these outputs, note:

pin 1 = output number 17 (trigger 1):

15 ohms to ground when closed (output low), open when off (output high, normal default); can be used to reset smoke detector power (must set “output normal low = yes” in *79 Menu mode, and set for zone type 54, fire zone reset, in *80 Menu mode); or can support 12V relay module[†] that draws less than 100mA

pin 5 = output number 18 (trigger 2):

100 ohms to ground when closed (output low); open when off (output high, normal default); or can support 12V relay module that draws less than 20mA

[†] e.g., Altronix AX-RSB

Phone Line/Phone Module Connections

1. Connect incoming phone line and handset wiring to the main terminal block (via an RJ31X jack) as shown in the Summary of Connections diagram at the back of this manual. Wire colors represent the colors of the cable to the RJ31X jack.

If using a phone module, continue with the following steps.

2. Make 12V (+) and (-) and data in and data out connections from the phone module to the control, using the connector cable supplied with the phone module, then insert the keyed connector at the other end of the connector cable into the header on the phone module.
3. Connect Phone Module terminals as shown below. Use an RJ31X jack with a direct-connect cord and make all connections exactly as shown.
4. Caller ID Units: If a Caller ID unit is being used, connect the unit directly to the “Handset” terminals (21 & 22) on the control, as shown.

NOTES

- Use FA4285 or FA4286 Phone Modules.
Compatibility: FA4286 Phone Modules must have software version WA4286-15.1 or higher (refer to the label on the square FA4286 microprocessor chip).
- Only one phone module can be used.
- The phone lines must be in service for the phone module to function, even when accessing the system from an on-premises phone.
- If you are also using an Audio Alarm Verification (AAV) unit, refer to *Audio Alarm Verification (AAV)* section for special wiring connections.

CAUTION: To reduce the risk of fire, use only No. 26 AWG or larger telecommunication line cord for phone line connections.

UL The FA4285 and FA4286 modules are UL Listed only for use on residential fire and UL residential burglar alarm installations.

Phone Module Problems

If no touch tones are produced following access to the security system from on-premises (this problem may arise in rare cases), it may be necessary to reverse the wires connected to terminals 3 and 4 on the phone module and the wires connected to terminals (21) & (22) on the control. The wiring diagram shows the wiring connections that will provide proper operation in most cases.

Connection to the incoming telco line via a RJ31X jack and direct-connect cord, as shown, is essential, even if the system is not connected to a central station. Otherwise the FA4285/FA4286 will not function and an error signal (fast busy signal) will occur when accessing the system via the phone.

The house phone lines (gray and brown wires) must be wired to the phone module terminals; not to the control terminals. Otherwise, an error signal (fast busy signal) will occur when trying to access the system from an on-premises phone.

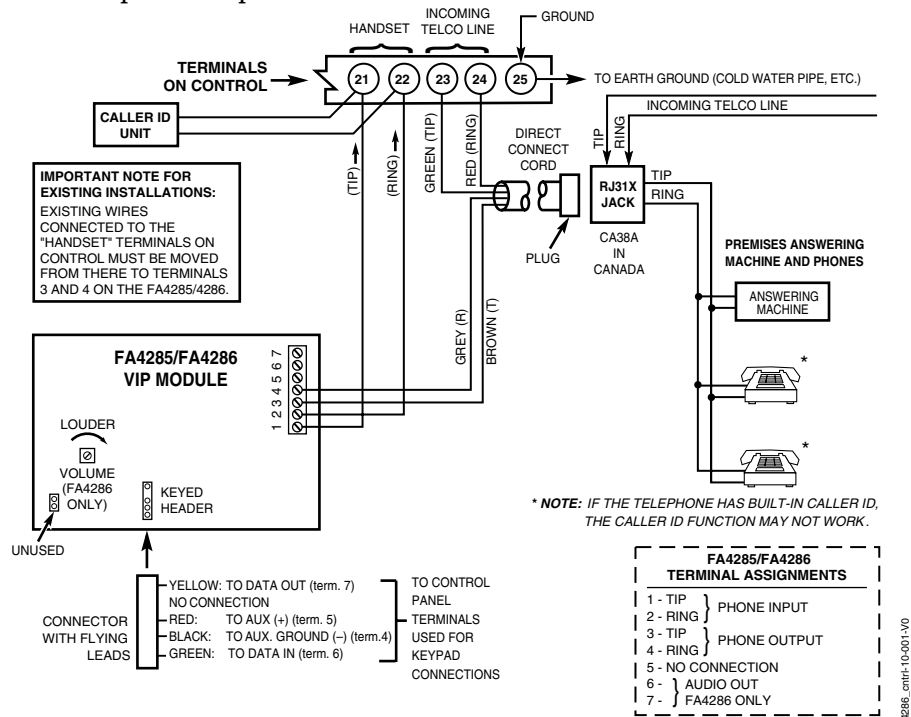

Figure 13. FA4285/FA4286 Phone Module Wiring Connections

Long Range Radio Connections

Connect the data in/data out terminals and voltage input terminals of the Long Range Radio to the control's keypad connection points.

Set the radio's address to "03" following the instructions provided with the radio.

Use compatible Long Range Radios (e.g., 7720PLUS, 7820, 7835C, or 7845C).

AAV Connections

Refer to the connection diagrams below. One diagram shows connections when a FA4285/FA4286 Phone Module is used, the other shows connections when the FA4285/FA4286 is not used. Connections use one of the on-board triggers.

UL UL installations using the AAV feature must use the ADEMCO UVCM module (part of the ADEMCO UVS system)

Suggested AAV Module: ADEMCO UVS (shown) or Eagle 1250

NOTES

- Set field *91 for AAV and program the appropriate output (output 17 or 18) using *80 Menu mode (select zone type “60”).
- For voice session monitoring, connect a zone to UVCM module terminals 6 & 7, and program the zone as zone type 81 (*56 Menu mode).
E.g., Using output 18 for the trigger, two output functions in *80 Menu mode should be:
ZT = 60, P = 0, Action = 1, Device = 18

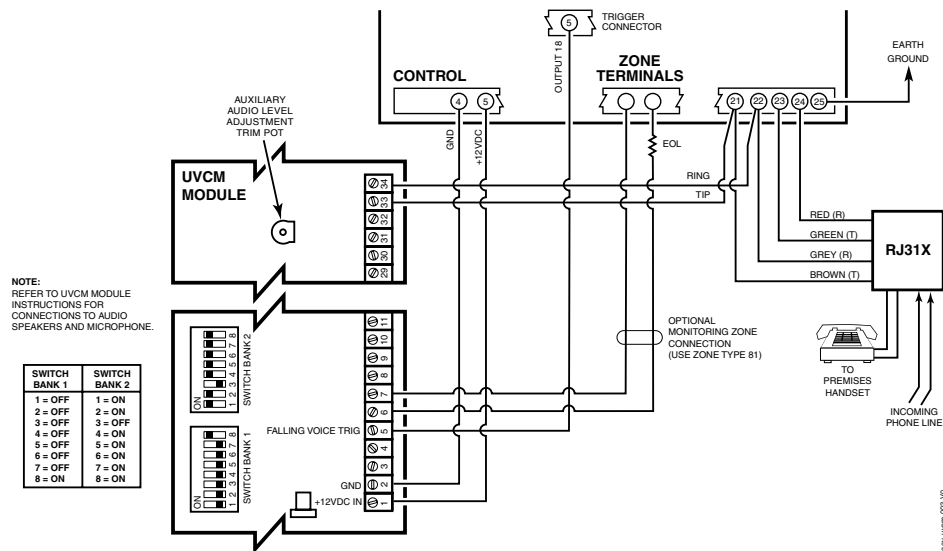

Figure 14. Connection of AAV Unit When Not Using an FA4285/FA4286 Phone Module

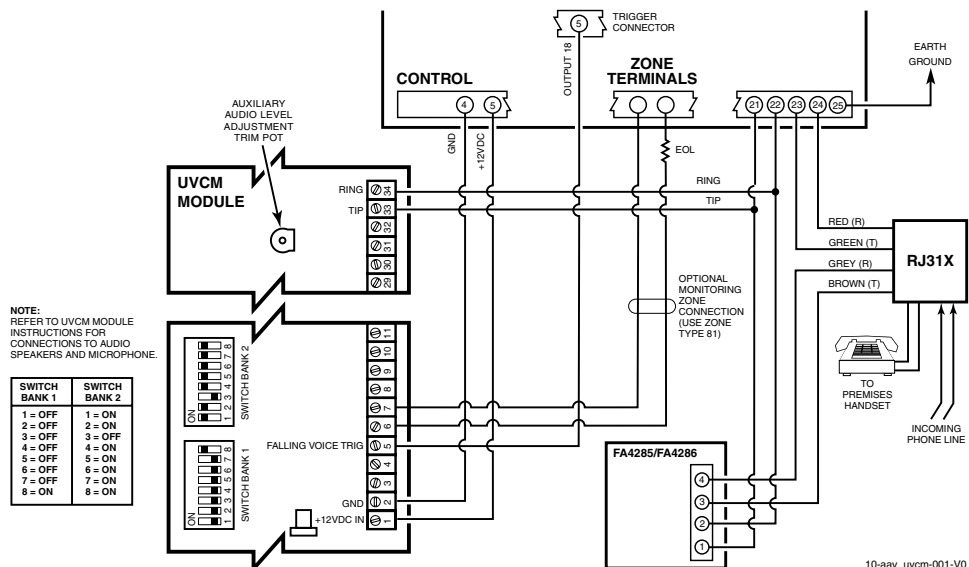

Figure 15. Connection of AAV Unit When Using an FA4285 or FA4286 Phone Module

Programming Overview

About Programming

You can program the system at any time, even at the installer's premises prior to the actual installation. Programming can also be performed remotely from the installer's office/home, using an IBM personal computer, a modem, and Compass downloading software.

The following is a list of the various Programming modes used to program this system:

Programming Mode...	Used to ...
Data Field Programming	Program basic data fields used for setting the various system options. Most of the data fields in this system have been programmed for specific default values. However, some fields must be programmed for each particular installation to establish its specific alarm and reporting features.
*56 Zone Programming	Assign zone characteristics, report codes, alpha descriptors, and serial numbers for 5800 RF transmitters.
*57 Function Key Programming	Program each of the four alphabet function keys to perform one of several system operations.
*58 Zone Programming	Assign zone attributes similar to *56 mode, but provides a faster programming procedure and is intended for those more experienced in programming controls of this type.
*79 Output Device Mapping	Assign device address of the 4204 Relay module and map the specific relays
*80 Output Definitions	Define up to 12 output definitions which can control the output relays mapped using *79 Output Device Mapping mode.
*81 Zone List Programming	Create Zone Lists for relay zones, chime, night-stay, and pager zones.
*82 Alpha Programming	Create alpha descriptors for easy zone identification.
Scheduling Mode (code + [#] +64)	Create schedules to automate various system functions.

Keypads

Keypads are identified by predefined addresses (starting at address 16) as follows:

Address	Keypad	Program Field
16	keypad 1*	• always enabled, all sounds enabled.
17	keypad 2	• data field *190
18	keypad 3	• data field *191
19	keypad 4	• data field *192
20	keypad 5	• data field *193
21	keypad 6	• data field *194
22	keypad 7	• data field *195
23	keypad 8	• data field *196

NOTE: First keypad is address 16.

To enable keypads:

1. Set desired address at keypad (refer to keypad's instructions for setting the address).
2. Use data field program mode to enable keypad addresses and enable sound options in fields *190-*196 as shown in the table above.
3. Set the following keypad-related data fields as required by the installation:
 - *21 Quick Arm Enable; *23 Forced Bypass; *84 Auto STAY Arm

Wireless Receiver, Transmitters, and Wireless Keys (keyfobs)

Receiver: Set the receiver's address to "00" using its DIP switches, then set the following options:

- *22 RF Jam Option†
- *24 RF House ID Code (if using wireless keypads)
- *67 Transmitter Low Battery Report Code†
- *75 Transmitter Low battery restore report code†
- *173 RF Reporting Options

† These fields must be enabled for Residential Fire, UL Residential Burglar Alarm, and UL Commercial Burglar Alarm installations.

Transmitters: Use *56 or *58 Zone Programming Menu modes to program zone information and enroll transmitters.

Wireless Keys: Use Wireless Key Programming Templates section of the *58 Zone Programming Menu mode to program zone information and enroll each button of the wireless keys used. Once a wireless key is enrolled, it must be assigned to a user before it becomes active. See Adding/Deleting Security Codes section for procedure.

Pager Programming

The system can send various reports to a pager.

To program pager reporting, do the following:

1. Enter the appropriate information in the following data fields:
 - *160, Pager Phone Number
 - *161, Pager Prefix Characters
 - *162, Pager Reporting Options
2. Enable Pager Delay, if desired, in field *172
3. Enable appropriate user open/close pager report using the user attribute command (master code + [8] + user no. + [#] [5] + [1]).
4. If using latchkey pager report, define the latchkey report schedule using Scheduling mode (master code + [#] [6] [4] then select event type "03").
5. If using a function key to manually send a message to a pager, see Function Keys paragraph on the next page.
6. If reporting zone alarms and troubles to a pager, use *81 Zone List menu mode to assign the zones associated with each pager (zone lists 9).

Function Keys

To assign functions to the function keys, use *57 Function Key menu mode.

To assign emergency key functions (function key option "00"), first program the respective emergency zone number (95 for "A" key, 96 for "C" key, 99 for "B" key) with the desired zone type using *56 Zone Programming mode, then use *57 Function Key menu mode to assign the desired key.

If using a function key to activate a relay action (*57 Menu mode key function 07), use *79 Menu mode to map the output, and use *80 Menu mode to define the output's action; select system operation type "66."

If using a function key for a user macro, use *57 menu mode to activate the desired key, then define the actual macro functions using the user code + [#] + [6] [6] command.

Output Devices

To program a device for manual activation (user code + [#] [7] / [#] [8] + 2-digit device number) or for scheduled automatic activation, simply map the device using *79 Menu mode.

To program a device to automatically activate upon a system event (or function key), use *79 Menu mode to map the device, then use *80 Menu mode to define the automated device action.

If the device action is based on more than one zone, use *81 Zone List menu mode to assign the zones.

Zone Type Definitions

You must assign a zone type to each zone, which defines the way in which the system responds to faults in that zone. Zone types are defined below.

Zone Type	Description
Type 00 Zone Not Used	Program a zone with this zone type if the zone is not used.
Type 01 Entry/Exit Burglary #1	<ul style="list-style-type: none"> • Assign to zones that are used for primary entry and exit. • Provides entry delay if control is armed in the Away, Stay, or Night-Stay modes. • No entry delay provided when the panel is armed in the Instant/Maximum mode. • Entry delay #1 is programmable from 30 to 240 seconds. • Exit delay begins whenever the control is armed, regardless of the arming mode selected, and is programmable from 45 to 180 seconds (field *34).
Type 02 Entry/Exit Burglary #2	<ul style="list-style-type: none"> • Assign to zones that are used for entry and exit and require more time than the primary entry/exit point. • Provides a secondary entry delay, in same manner as entry delay #1. • Entry delay #2 is programmable from 30 to 240 seconds. • Exit delay is same as described for Type 01.
Type 03 Perimeter Burglary	<ul style="list-style-type: none"> • Assign to all sensors or contacts on exterior doors and windows. • Provides an instant alarm if the zone is faulted when the panel is armed in the Away, Stay, Night-Stay, Instant or Maximum modes.
Type 04 Interior Follower	<ul style="list-style-type: none"> • Assign to a zone covering an area such as a foyer, lobby, or hallway through which one must pass upon entry (to and from the keypad). • Provides a delayed alarm (using the programmed entry/exit time) if the entry/exit zone is faulted first. Otherwise this zone type gives an instant alarm. • Active when the panel is armed in the Away mode. • Bypassed automatically when the panel is armed in the Stay or Instant modes; if armed in Night-Stay mode, zones assigned to zone list 05 (night-stay zone list) are not bypassed when system armed in Night-Stay mode.
Type 05 Trouble by Day/ Alarm by Night	<ul style="list-style-type: none"> • Assign to a zone that contains a foil-protected door or window (such as in a store), or to a zone covering a sensitive area such as a stock room, drug supply room, etc. • Can also be used on a sensor or contact in an area where immediate notification of an entry is desired. • Provides an instant alarm if faulted when armed in the Away, Stay, Night-Stay, Instant or Maximum (night) modes. • During the disarmed state (day), the system will provide a latched trouble sounding from the keypad (and a central station report, if desired).
Type 06 24-hour Silent Alarm	<ul style="list-style-type: none"> • Usually assigned to a zone containing an emergency button. • Sends a report to the central station but provides no keypad display or sounding.
Type 07 24-hour Audible Alarm	<ul style="list-style-type: none"> • Assign to a zone that has an emergency button. • Sends a report to the central station, and provides an alarm sound at the keypad, and an audible external alarm.
Type 08 24-hour Auxiliary Alarm	<ul style="list-style-type: none"> • Assign to a zone containing an emergency button, or to a zone containing monitoring devices such as water or temperature sensors. • Sends a report to the central station and provides an alarm sound at the keypad. (No bell output is provided.)
Type 09 Supervised Fire	<ul style="list-style-type: none"> • Provides a fire alarm on short circuit and a trouble condition on open circuit. A fire alarm produces a pulsing bell output. • This zone type is always active and cannot be bypassed.
Type 10 Interior w/Delay	<ul style="list-style-type: none"> • Provides entry delay (using the programmed entry time), if tripped when the panel is armed in the Away mode. • Entry Delay 1 begins whenever sensors in this zone are violated, regardless of whether or not an entry/exit delay zone was tripped first. • Bypassed when the panel is armed in the Stay or Instant modes; if armed in Night-Stay mode, zones assigned to zone list 05 (night-stay zone list) are not bypassed when system armed in Night-Stay mode.

<p>Type 12 Monitor Zone</p>	<ul style="list-style-type: none"> • Works as a dynamic monitor of a zone fault/trouble (not alarm). In the case of a short/open, the message, "*ALARM*-24 Hr. Non-Burg. -#XXX " (where XXX is the zone number) will be sent to the Central Station. The system keypad will display a "check" message indicating the appropriate zone (but keypad beeping does not occur). Upon restoral of the zone, the message, "*RESTORE*-24 Hr. Non-Burg. -#XXX " will be sent to the Central Station. • The "check" message will automatically disappear from the keypad dynamically, when the zone restores; a user code + off sequence is not needed to reset the zone. • Faults of this zone type are independent of the system, and can exist at the time of arming without interference. • Since this is a "trouble" zone type, do not use this zone type with relays set to activate upon "alarm."
<p>Type 14 24 Hour Carbon Monoxide Monitor</p>	<ul style="list-style-type: none"> • Assigned to any zone with a carbon monoxide detector. • The bell output will pulse when this zone type is alarmed. • Always active and cannot be bypassed.
<p>Type 16 Fire w/Verification</p>	<ul style="list-style-type: none"> • Provides a fire alarm when zone is shorted, but only after alarm verified. • System verifies alarm by resetting zones for 12 seconds after short is detected. A subsequent short circuit within 90 seconds triggers fire alarm. • Provides a trouble response when zone is open.
<p>Type 20 Arm-Stay (BR only)</p>	<ul style="list-style-type: none"> • Arms the system in Stay mode when the zone is activated. • Pushbutton units send the user number to the central station when arming or disarming. • User number for button must be assigned.
<p>Type 21 Arm-Away (BR only)</p>	<ul style="list-style-type: none"> • Arms the system in Away mode when the zone is activated. • Pushbutton units send the user number to the central station when arming or disarming. • User number for button must be assigned.
<p>Type 22 Disarm (BR only)</p>	<ul style="list-style-type: none"> • Disarms the system when the zone is activated. • User number for button must be assigned.
<p>Type 23 * No Alarm Response</p>	<ul style="list-style-type: none"> • Can be used on a zone when an output relay action is desired, but with no accompanying alarm (e.g., lobby door access).
<p>Type 24 Silent Burglary</p>	<ul style="list-style-type: none"> • Usually assigned to all sensors or contacts on exterior doors and windows where bells and/or sirens are NOT desired. • Provides an instant alarm, with NO audible indication at any keypad or external sounder, if the zone is faulted when the system is armed in the Away, Stay, Instant, or Maximum modes. • A report is sent to the central station.
<p>Type 77 Keyswitch</p>	<ul style="list-style-type: none"> • Assign to zone wired to a keyswitch. • Do not use devices assigned as input type "BR" with this zone type.
<p>Type 81 AAV Monitor Zone</p>	<ul style="list-style-type: none"> • Assign to zone connected to AAV module. • Monitors 2-way voice sessions as follows: <ul style="list-style-type: none"> - When the zone is faulted, all alarm sounding and dialer reporting stops, except for fire alarms, which immediately terminate the voice session and cause a fire report to be sent. - When the zone is restored (session ended), sounding resumes (if bell timeout has not expired) and reports that were stopped are sent.
<p>Types 90 Configurable</p>	<p>Allows for a custom zone response. Options include response to entry/exit delays, response opens/shorts, types of alarm/trouble sounding, dial delay, and unique Contact ID report code.</p> <p>UL installations: Zone Type 90 may not be used as fire or burglar alarm zones on fire or UL burglar alarm installations.</p>

* The system can still be armed when these zone types are in a faulted condition.

NOTE: All of the zone types described are available for the wireless portion of the system, if used.

Mechanics of Programming

Data Field Programming Procedures (You must use a 2-line Alpha display keypad)

Task	Procedure
Entering Program Mode	A) Press both [*] and [#] at the same time within 50 seconds after power is applied to the control, OR B) After power-up, enter [Installer code (4-1-1-2)] + 8 0 0. (method “B” is disabled if you exit the program mode using *98)
Go to a Data Field	Press [*] + [Field Number] (for example, *21). A display of “EE” or “Entry Error” means you have entered a nonexistent field. Simply re-enter [*] plus a valid field number.
Entering Data	When the desired field number appears, simply enter the digits required. The keypad beeps three times after the last digit is entered and automatically displays the next data field in sequence. If entering less than the maximum digits available (e.g., phone number field), enter the desired digits, then press [*] to end the entry.
Review a Data Field	Press [#] + [Field Number]. Field data is displayed, but no changes can be made.
Deleting an Entry	Press [*] + [Field No.] + [*] (applies only to phone number, account number, and pager character fields).

Menu Mode Programming (*56, *57, *58, *79, *80, *81, *82)

Entering Menu Mode	Press [*] + [Menu Mode No.] (for example, *56) while in Program Mode. The Alpha display keypad displays the first of a series of prompts. After making the appropriate entry, press the [*] key to accept the entry and continue to the next prompt.
--------------------	---

Loading Factory Defaults/Initializing for Download

To Load Default Entries	Press *97 while in Program Mode. This resets all data fields to the default values shown on the Program Form. Use *97 only if you wish to return to the original factory-programmed defaults. Do not press *97 to load defaults if any programming has been done previously—data already programmed into the system will be changed!
To Initialize Download ID	Press *96 while in Program Mode. This initializes the system for downloading and resets all the subscriber account numbers and CSID.

Exiting the Programming Mode

Prevent installer code reentry	Press *98. Exits Programming Mode and prevents re-entry by: Installer Code + [8] + [0] + [0]. To enter the programming mode if * 98 was used to exit, you must first power the system down. Then power up again, and press [*] and [#] at the same time, within 50 seconds of powering up. See field *88 for other Program mode lockout options.
Allow installer code reentry	Press *99. Exits Program Mode and allows re-entry by method A or B above.

Table of Device Addresses

This Device	Uses Address	Reports as ^{††}	Enabled By...
RF Receiver	00	100	*56 zone programming: input device type entry
Long Range Radio	03	103	automatic if output to long range radio field *29 enabled
FA4286 Voice Module	04	104	automatic if phone module access code field *28 enabled
4204 Relay Module	12	112	*79 output device programming: entered at device address prompt:
Keypads:			data field programming as listed below:
keypad 1	16	n/a	always enabled, all sounds enabled.
keypad 2	17	n/a	data field *190
keypad 3	18	n/a	data field *191
keypad 4	19	n/a	data field *192
keypad 5	20	n/a	data field *193
keypad 6	21	n/a	data field *194
keypad 7	22	n/a	data field *195
keypad 8	23	n/a	data field *196
5800TM Module	28	n/a	automatic

† †Addressable devices are identified by “1” plus the device address when reporting. Enter a report code for zone 91 to enable addressable device reporting (default = reports enabled). See field *199 for addressable device (ECP) 3-digit/2-digit identification keypad display options.

Data Field Programming

About Data Field Programming

The following pages provide explanations of this control's data fields and is intended to be used in conjunction with the *Programming Guide*. Refer to the *Programming Guide* for the specific option choices for each data field.



Use the blank programming form to record the data for this installation.

Programming Data Fields

Data field programming involves making the appropriate entries for each of the data fields. Start Data Field programming by entering the installer code + 8 + 0 + 0.

System Setup Fields

FIELD	TITLE and EXPLANATION
*20	Installer Code Enter a 4-digit Installer Code. This code can perform all system functions except it cannot disarm the system unless it is used to arm the system.
*21	Quick Arm Enable Select whether or not users can press the [#] key in place of entering a security code when arming the system (e.g., to arm AWAY, press [#] + AWAY). If not selected, users must enter a security code to arm the system. In either case, the user code is always needed to disarm the system.
*22	RF Jam Option Select whether or not the system sends an RF jam report if an RF jamming signal is detected. UL installations must be 1 if wireless devices are used.
*23	Quick (Forced) Bypass Select whether or not the Quick Bypass command (code +[6] + [#]) is active. Zones bypassed by this function will be displayed after the bypass is initiated. UL installations must be 0 (no forced bypass)
*24	RF House ID Code Enter the RF House ID, which identifies receivers and wireless keypads. If a 5827 or 5827BD Wireless Keypad or 5804BD Transmitter is being used, a House ID code must be entered, and the keypad set to the same House ID.
*26	Chime By Zone List 3 Select if you want a list of specific zones to chime when faulted while the system is in Chime mode (use zone list 3 to assign these zones; see *81 <i>Zone List Programming</i> section for details). If not selected, all entry/exit and perimeter zones will chime when faulted and system is in Chime mode.
28	Access Code for Phone Module Enter a 2-digit access code for the FA4285/FA4286 Phone Module, if used. Example: If desired access code is 7 , 7 is the first entry, and [#] + 11 (for *) is the second entry. NOTE: A "0" in either digit disables the phone module. Must be "00" for UL Commercial Burglar Alarm installations.
*29	Long Range Radio Output Select whether or not all messages programmed to go to the primary telephone line receiver will also be sent to the connected 7720PLUS, 7820, 7835, or 7845 Radio (sent in Contact ID format). The data line is supervised as well as certain functions in the radio. If communication is lost or a trouble develops, an attempt will be made to send a message via both radio and telephone to the central station. Program the radio for device address 3.

Zone Sounds & Timing

FIELD	TITLE and EXPLANATION
*31	Single Alarm Sounding Per Zone Select whether or not the system limits alarm sounding to once per arming period for a given zone. UL installations must be 0 (no limit).
*32	Fire Alarm Sounder Timeout Select whether or not alarm sounding continues until manually turned off (ignores sounder timeout). If not selected, sounding stops at timeout programmed in *33. This control complies with NFPA requirements for temporal pulse sounding of fire notification appliances. Temporal pulse sounding for a fire alarm consists of the following: 3 pulses – pause – 3 pulses – pause – 3 pulses. UL fire alarm installations: must be 1.
*33	Alarm Sounder Timeout Enter the desired alarm sounding time. Entering “0” lets sounding continue until manually turned off. UL installations: For residential fire alarm installation, must be set for a minimum of 4 min (option 1); for UL Commercial Burglary installations, must be minimum 16 min (option 4).
*34	Exit Delay Enter the desired time the system waits before arming entry/exit zones. If the entry/exit door is left open after this time expires, an alarm will occur. UL installations: For UL Commercial Burglar Alarm (Grade AA) and UL Residential Burglar Alarm installations with line security, total exit time must not exceed 60 seconds. For UL Burglar Alarm installations without line security (Grade A), total exit time must not exceed 120 seconds. SIA Installations: minimum exit delay is 45 seconds
*35	Entry Delay 1 Enter the desired time within which the system must be disarmed after opening an entry door. If this time expires without disarming, an alarm occurs. UL installations: For UL Residential Burglary Alarm installations, must be set for a maximum of 30 seconds; entry delay plus dial delay should not exceed 1 min. For UL Commercial Burglar Alarm, total entry delay may not exceed 45 seconds. SIA Installations: minimum entry delay is 30 seconds
*36	Entry Delay 2 Use this entry for a secondary entry door. See *35 above for explanation.
*37	Audible Exit Warning Select whether or not you want exit warning sounds, which consist of slow continuous beeps until the last 10 seconds, then it changes to fast beeps. Sound ends when exit time expires. SIA Installations: must be enabled (enter 1)
*38	Confirmation Of Arming Ding Select whether and when you want a confirmation of arming “ding” (1/2 second external sounder “ding”). If “1” selected, ding occurs when closing report is sent, or at the end of Exit Delay. If “2” selected, ding occurs upon reception of the wireless arming command. UL installations: must be “1” for UL Commercial Burglar Alarm installations.
*39	Power-Up In Previous State Select whether or not the system powers up in its previous state (if the system powers up armed and a zone is faulted, an alarm will occur 1 minute after power up). Note that if the previous state was armed Away or Stay, the system will not respond to sensor changes for 1 minute, which allows time for sensors such as PIRs to stabilize. UL installations: must be 1 (power-up in previous state)

Dialer Programming

FIELD	TITLE and EXPLANATION
*40	PABX Access Code Enter the PABX code, if used. To clear entries from field, press *40*. If fewer than 6 digits need to be entered, exit by pressing [*], which advances to the next field. Call Waiting: If the subscriber's phone service has "call waiting" (and is not using PABX), enter "**70" ("# + 11") plus "# + 13" (pause) as the PABX entry to disable "call waiting" during control panel calls. If the subscriber does not have "call waiting" and is not using PABX, make no entry in this field.
41	Primary Phone No. Enter the primary phone number. If you enter fewer than 20 digits, exit by pressing []. To clear entries from field, press *41*. NOTE: Backup reporting (in which 8 calls are made to the secondary phone number if no kissoff is received after 8 attempts to the primary number) is automatic only if there is a secondary phone number (field *42).
42	Secondary Phone No. Enter the secondary phone number. If you enter fewer than 20 digits, exit by pressing []. To clear entries from field, press *42*. See backup reporting note for field *41. Don't fill unused spaces.
*43	Primary Subs. Acct. No. Enter the primary subscriber account number. To clear entries from field, press *43*.
*44	Secondary Subs. Acct. No. Enter the secondary subscriber account number. To clear entries from field, press *44*.
*47	Phone System Select Select whether the system will be using pulse or tone dialing, and whether it is on a WATS line.
*48	Report Format (Primary/Secondary) Select the desired report format for primary and secondary phone numbers from the list shown on the Programming Guide.
*49	Split/Dual Reporting Select the desired type of reports to be sent to the primary/secondary numbers. Make selection from the table in the Programming Guide. If "0" selected, all reports go only to the primary number unless unsuccessful, then control will attempt to dial secondary number.
*50	Burglary Dialer Delay Enter the desired delay time (none, 15, 30, or 45 seconds) before a "BURGLARY ALARM" report is sent to the central station. This delay allows time for the subscriber to avoid sending a false alarm if the alarm was inadvertently caused. This delay does not apply to zone type 24 alarms (silent burglary) or to 24-hour zone types 6, 7, and 8 (silent panic, audible alarm, auxiliary alarm), which are always sent as soon as they occur. UL: must be "0"; SIA Installations: delay must be minimum of 30 seconds
*53	SESCOA/Radionics Select Select whether SESCOA format is used.
*54	Dynamic Signaling Delay Intended for use with Long Range Radio reporting. Enter the desired time (0-255 seconds in 15-second increments) the panel should wait, per message, for acknowledgment from the first reporting destination (see *55) before it attempts to send a message to the second destination. Entering "0" sends redundant reports to both Primary Dialer and LRR. UL Installations: For Fire Alarm and UL Burglar Alarm installations without Line Security (Grade A), the maximum Dynamic Signaling Delay must be no more than 15 seconds. For UL Burglar Alarm installations with Line Security (Grade AA), Dynamic Signaling Delay must be "0". The reports will be sent to both the dialer and the LRR.

***55 Dynamic Signaling Priority**

UL Installations: For UL Commercial Burglary installations that use a DACT and LRR, the DACT must be programmed for priority (option "0").

Intended for use with Long Range Radio reporting (field *29 OUTPUT TO LONG RANGE RADIO must be enabled).

Select the initial reporting destination for messages as follows:

Primary Dialer First selected (0):

- If acknowledged before delay expires (see *54), then message will not be sent to LRR.
- If not acknowledged before delay expires, then message is sent to both the Primary Phone No. and LRR.

Long Range Radio First selected (1):

- If acknowledged before delay expires, then message will not be sent to the primary dialer.
 - If not acknowledged before delay expires, then message is sent to both the Primary Phone No. and LRR.
-

***56 Zone Programming Menu Mode**

Use this menu mode to program zone information. See Zone Programming section for procedures.

***57 Function Key Menu Mode**

Use this menu mode to program keypad function keys. See Function Key section for procedures.

***58 Expert Zone Programming Menu Mode**

This menu mode can be used to quickly program zone information, but is recommended only for those already familiar with *56 menu mode. See Zone Programming section for procedures.

System Status Report Codes

Zone report codes are programmed using interactive *56 or *58 Zone Programming modes, while system status (non-alarm) codes and restore codes are entered in data fields *59 - *76. The actual report code digits that you enter depend upon the particular installation, and should agree with the Central Station office receiving the signals.

3+1 or 4+1 Standard Format: Enter a code in the first box: 1–9, A, B, C, D, E, or F. Enter #+10 for A (this reports a 0 on some receivers), #+11 for B, #+12 for C, #+13 for D, #+14 for E, #+15 for F.

An entry of 0 in the first box disables a report. Entering 0 in the second box advance to the next field.

Expanded or 4+2 Format: Enter codes in both boxes (first and second digits) for 1–9 or A–F, as described above. "0" in the first box disables a report. "0" in the second box eliminates the expanded message for that report.

ADEMCO Contact ID® Reporting: Enter a digit in the first box to enable the zone to report. Use a different digit for each zone until you have used up available digits. If the number of zones exceeds the number of available digits, begin with digit 1 again. This is an "enabling" code only and is not the actual code sent to the Central Station office. Entries in the second boxes are ignored. An entry of 0 in the first box disables the report.

UL installations: Program fields *59 - *76 as required by applicable UL Standards shown in each field.

FIELD	TITLE and EXPLANATION
-------	-----------------------

*59	Exit Error Report Code
------------	-------------------------------

After arming the system, zones remaining open after exit delay expires cause an alarm sound at the keypad and external sounder (keypad also displays "EXIT ALARM"), and entry delay begins. Disarming before the end of the entry delay stops the alarm sounding and no message is sent to the central station. The keypad will display "CA" (fixed-word) or "CANCELED ALARM" (alpha display). If the system is not disarmed before entry delay expires, an "EXIT ALARM" message will be sent to the central station if Exit Error Report Code is enabled. The keypad will display "EA" (fixed-word) or "EXIT ALARM" (alpha display), and alarm sounding continues until the system is disarmed (or timeout occurs).

An Exit Alarm condition will also result if a fault occurs in an exit or interior zone within 2 minutes following the end of the exit delay, and an "EXIT ALARM" message will be sent to the central station.

*60	Trouble Report Code
------------	----------------------------

Enter the appropriate report code, which is sent if a zone has a trouble condition.

UL: Required for UL commercial burglar alarm installations and required for residential fire alarm installations.

*61	Bypass Report Code
------------	---------------------------

Enter the appropriate report code, which is sent when a zone is manually bypassed.

UL: Required for UL commercial burglar alarm installations.

FIELD	TITLE and EXPLANATION
*62	<p>AC Loss Report Code</p> <p>Enter the appropriate report code. Timing of this report is random with up to a 4-hour delay. If AC restores before the report goes out, there is no “AC RESTORE” report.</p> <p>UL: Required for UL commercial burglar alarm installations and required for residential fire alarm installations.</p>
*63	<p>Low Bat Report Code</p> <p>Enter the appropriate report code; sent when a low-battery condition exists in the system’s battery.</p> <p>UL: Required for UL commercial burglar alarm installations and required for residential fire alarm installations.</p>
*64	<p>Test Report Code</p> <p>Enter the appropriate report code, which is sent periodically to test that the communicator and phone lines are operational. Frequency of report is set in Scheduling mode (event 11) or by the following key commands:</p> <p style="padding-left: 40px;">installer code + [#] + 0 + 0 = test report sent every 24 hours</p> <p style="padding-left: 40px;">installer code + [#] + 0 + 1 = test report sent once per week</p> <p style="padding-left: 40px;">installer code + [#] + 0 + 2 = test report sent every 28 days</p> <p>Each mode sets schedule 2 to the stated repeat option; first test report sent 12 hours after command.</p> <p>NOTE: Make sure the Real-Time Clock is set to the proper time before entering the test report schedule command to ensure that test reports are sent when expected. (see Setting the Real-Time Clock section).</p> <p>UL: Required for UL commercial burglar alarm installations and required for residential fire alarm installations.</p>
*65	<p>Open Report Code</p> <p>Enter the appropriate report code, which is sent upon disarming of the system.</p> <p>UL: Required for UL commercial burglar alarm installations.</p>
*66	<p>Arm Away/Stay Report Code</p> <p>Enter the appropriate report code.</p> <p>NOTE: “OPEN” reports are not sent if the associated closing report is not enabled.</p>
*67	<p>RF Trans. Low Batt. Report Code</p> <p>Enter the appropriate report code; sent when a wireless transmitter low-battery condition exists.</p> <p>UL installations: must be enabled if wireless devices are used.</p>
*68	<p>Cancel Report Code</p> <p>Enter the appropriate report code, which is sent upon disarming of the system after an alarm condition was reported.</p>
*70	<p>Alarm Restore Report Code</p> <p>Enter the appropriate report code; sent when an alarm zone is restored to its non-faulted condition.</p> <p>UL: Required for UL commercial burglar alarm installations and required for residential fire alarm installations.</p>
*71	<p>Trouble Restore Report Code</p> <p>Enter the appropriate report code, which is sent when a trouble in a zone is restored</p> <p>UL: Required for UL commercial burglar alarm installations.</p>
*72	<p>Bypass Restore Report Code</p> <p>Enter the appropriate report code, which is sent when a zone that has been bypassed is unbypassed.</p> <p>UL: Required for UL commercial burglar alarm installations.</p>
*73	<p>AC Restore Report Code</p> <p>Enter the appropriate report code; sent when AC power has been restored after an AC power outage.</p> <p>UL: Required for UL commercial burglar alarm installations and required for residential fire alarm installations.</p>
*74	<p>Low Bat Restore Report Code</p> <p>Enter the appropriate report code; sent when a system low-battery condition is restored to normal.</p> <p>UL: Required for UL commercial burglar alarm installations and required for residential fire alarm installations.</p>
*75	<p>RF Xmtr Low Batt. Restore Code</p> <p>Enter the appropriate report code, which is sent when a transmitter’s low battery condition is restored (i.e., new battery installed).</p> <p>UL installations: must be enabled if wireless devices are used. Required for UL commercial burglar alarm installations and required for residential fire alarm installations.</p>

FIELD	TITLE and EXPLANATION
*76	Test Restore Report Code Enter the appropriate report code, which is sent when the Test mode is exited. UL: Required for UL commercial burglar alarm installations and required for residential fire alarm installations.

Miscellaneous System Fields

FIELD	TITLE and EXPLANATION
*77	Daylight Saving Time Start/End Month Enter the start and end month for daylight savings time, if applicable to the region.
*78	Daylight Saving Time Start/End Weekend Enter the start and end weekend for daylight savings time, if applicable to the region.
*79	Output Device Mapping Menu Mode Use this menu mode to enter output devices/powerline carrier devices into the system. See Output Device Programming section for procedures.
*80	Output Programming Menu Mode Use this menu mode to define output functions for use with output devices/powerline carrier devices. See Output Programming section for procedures.
*81	Zone List Programming Menu Mode Use the menu mode to define zone lists. See Zone List Programming section.
*82	Alpha Descriptor Programming Menu Mode Use this menu mode to assign alpha descriptors to zones.
*84	Auto-Stay Arm Select whether or not Auto-Stay arm is active. If selected, and system armed in AWAY mode at a keypad (non-RF device), the system automatically reverts to armed STAY (or INSTANT) mode if a door is not opened and shut within the programmed exit delay time. An Opening report followed by an Armed Stay report is sent to the Central Station. Any RF device that arms the system AWAY overrides this feature and the system remains armed in the AWAY mode.
*85	Cross Zone Timer (in seconds) Select the maximum amount of time in which two cross zones must be tripped in an armed system to send an alarm message to the Central Station. If only one cross zone is tripped during this time, a trouble message (CID code 380) for that zone is sent to the Central Station. Assign cross zone pairs in zone list 4. This option not for use in UL installations.
*86	Cancel Verify Keypad Display Select whether or not you want a “ CANCELED ALARM ” display on the LCD keypad under the following conditions: <ul style="list-style-type: none"> • After the kissoff of the cancel message to the Central Station, indicating a successful transmission. • When an alarm is successfully canceled before the Central Station received the Alarm message. E.g., if an alarm is incorrectly triggered and the user presses code + OFF before the dial delay time has expired, the message will never go out to the CS. • When the Cancel report is not enabled and the system is disarmed: <ol style="list-style-type: none"> a. before dialer delay expires (alarm report not sent) message “Canceled Alarm” is displayed. b. after dialer delay expires message “Canceled Alarm” is not displayed.
*87	Misc. Fault Delay Time Enter the desired fault delay time. Used with zones assigned to a configurable zone type with fault delay on (configurable zone type digit “6”), and sets a zone response time of 15 seconds to 15 min. It can be assigned to zones with sensors that provide a trouble indication when an oil tank is low, or similar applications for critical condition monitoring where a non-alarm response is desired. UL: May only be used on non-burglar alarm and non-fire alarm zones when used on a fire and/or UL burglar alarm installation.

FIELD	TITLE and EXPLANATION
-------	-----------------------

*88	<p>Program Mode Lockout Options</p> <p>0 = standard *98 installer code lockout (reentry only by [*] + [#] within 50 seconds after power up or downloader)</p> <p>1 = lockout [*] + [#] reentry after *98 exit (reentry only by installer code or downloader)</p> <p>2 = not used</p> <p>3 = lockout all local programming after *98 exit (reentry by downloader only)</p>
------------	--

*89	<p>Event Log Full Report Code</p> <p>Enter the appropriate report code, which is sent when the event log is 80% full (if an event log enable is made in field *90). If the log becomes full, new messages overwrite the oldest messages in the log.</p>
------------	--

*90	<p>Event Log Enables</p> <p>Select the types of events (up to 32 events) the system should log. The downloader operator can then upload the log and view or print out all or selected categories of the log. The downloader operator can also clear the log. The Event log can also be viewed at an alpha keypad.</p> <p>The display/printout at the central station will show the date, time, event, and description of the occurrences.</p> <p>Data Entry Example: To select Alarm/Alarm Restore” and “Open/Close”, enter 9 (1+ 8); to select all events, enter #15.</p>
------------	---

91	<p>Option Selection</p> <p>Select the desired options by adding the values of each desired option. Multiple choice example: for both AAV and Exit delay restart, enter # + 12 (4 + 8).</p> <p>“Exit Delay Restart/reset” option allows use of the [] key to restart the exit delay at any time when the system is armed STAY or INSTANT. This feature also enables automatic exit delay reset, which resets exit delay if the entry/exit door is re-opened before exit delay time expires after arming AWAY.</p> <p>IMPORTANT: AAV should not be used when Paging or Alarm Reports are sent to a secondary number unless the monitoring zone option is used (which pauses calls). Otherwise, the call to the secondary number by the communicator after the alarm report will prevent the AAV from taking control of the telephone line, and the AAV “Listen in” session cannot take place.</p>
------------	--

UL UL installations using the AAV feature must use the ADEMCO UVCM module (part of the ADEMCO UVS system). Exit Delay Restart/Reset must be disabled.

FOR SIA INSTALLATIONS: Exit delay should be enabled.

*93	<p>No. of Reports In Armed Period per Zone (Swinger Suppression)</p> <p>Select the number (0, 1, or 2) of alarm/alarm restore messages per zone allowed to be sent to the central station in an armed period.</p> <p>UL installations must be 0 (unlimited reports).</p>
------------	---

*94	<p>Download Phone Number</p> <p>Enter the downloading computer phone number.</p> <p>Do not fill unused spaces. End field by entering *. To clear entries from field, press *94*.</p>
------------	---

*95	<p>Ring Count For Downloading</p> <p>Refer to the chart below and program this field accordingly.</p>
------------	--

phone module	answer machine	down-loading	Set field *95 to...
yes	no	no	1-14 (not 0)
yes	yes	no	higher than number of rings set on answer machine (e.g., if ans. machine is 4 rings, set this field to 5). This allows access to the phone module if the answer machine is turned off.
yes	no	yes	1-14 (not 0)
yes	yes	yes	15 (bypasses answer machine [†])
no	no	no	0
no	yes	no	0
no	no	yes	1-14
no	yes	yes	15

[†] **NOTE:** If “15” is entered to bypass an answering machine, and an FA4285 or FA4286 Phone Module is included in the system, you should note the following:

When calling in from an off-premises phone, the user should make the initial call, allow 1 or 2 rings only, then hang up, then call again. The phone module will now seize the line, and 2 long tones sound, followed by the usual voice prompt for the access code. If this procedure is not followed, phone module operation will not be possible.

Configurable Zone Type Programming Fields

The system allows you to define a custom zone type, based on the options described below. This configurable zone types can be programmed via the downloader or from a keypad using data fields *182-*183 described below.

UL installations: Do not configure zones as fire alarm or UL burglar alarm zones.

FIELD	TITLE and EXPLANATION
-------	-----------------------

*182	<p>Configurable Zone Type 90 Enter the appropriate value for each entry, 1-10, based on the charts on the next page. To calculate the value for each entry, add the values of the selected options in each of the entry's columns shown in the respective chart (one option per column). For example, to program entry 2 for "alarm response to short," "auto restore on," but not a "vent zone," enter 5 ("1" for alarm short + "4" for auto restore-yes + "0" for vent zone-no).</p>
-------------	--

183	<p>Zone Type 90 Report Codes Enter the desired 3-digit Contact ID® report codes for alarms and troubles occurring on zones assigned to this zone type. Press [] to accept and continue.</p> <p>Important Notice on Report Codes: To avoid confusion at the central station, it is recommended that existing Contact ID® codes be used with configurable zone types whenever possible. See list in <i>System Communication</i> section and/or check with the central station for a complete list of Contact ID® report codes. If none of the codes are suitable, choose a code in the reserved range of 750-789 (reserved for configurable zone type report codes) and make sure to define the code with your central station.</p>
-------------	--

Configurable Zone Type Options	
Auto Restore (entry 2)	Faults on zones set for this option are cleared; restore messages sent upon restoral of faults.
Vent Zone (entry 2)	Zones set for this option are ignored if faulted when arming the system, but are protected if the zone is later restored (e.g., an open window can be ignored when arming, but if the window is later closed, it will be protected; opening the window again causes an alarm.)
Bypass Disarmed (entry 4)	Zones set for this option can be bypassed only while the system is disarmed.
Bypass Armed (entry 4)	Zones set for this option can be bypassed when the system is armed or disarmed.
Dial Delay (entry 6)	Alarms on zones set for this option participate in dial delay central station reporting, if system dial delay enabled in field *50.
Fault Delay (entry 6)	Faults on zones set for this option are delayed by the time set in field *87. Do not use this option if using entry/exit delay for this zone type.
Faults Display (entry 7)	Selects how faults on zones set for this zone type are displayed.
Power Reset/Verification (entry 7)	Selects whether the system resets power (when user enters code + OFF), and whether the system performs alarm verification (see description for zone type 16 in <i>Programming Overview</i> section) when a fault occurs on these zones.
Use Entry Delay (entry 8)	Selects whether to use the system's entry delay times.
Use Exit Delay (entry 8)	Selects whether to use the system's exit delay time.
Interior Type (entry 8)	Zones set for this option are treated same as standard zone type 4 (bypasses when armed STAY, faults displayed).
Alarm Sounds (entry 9)	Selects the type of alarms sound for zones set for this zone type.
Bell Timeout (entry 9)	Alarm sounding on zones set for this option remain for the duration set in fields *32/*33.
Fire Zone (entry 9)	Zones set for this option respond in the same manner as if programmed for zone type 9. Do not set fire zones to respond as a "fault" in entries 1-6.
Trouble Sounds (entry 10)	Selects the type of trouble sounds for zones set for this zone type (periodic beeps = once every 30 seconds; trouble beeps = rapid beeping).
Chime Enable (entry 10)	Zones set for this option cause a chime when Chime mode is on.

Configurable Zone Type Charts

ENTRY 1		ENTRY 2		
Response when system disarmed and zone is:				
Intact EOL RF zone normal	Open RF zone N/A	Shorted RF zn off-normal	Auto Restore	Vent Zone
0 = normal 1 = alarm 2 = trouble 3 = fault	0 = normal 4 = alarm 8 = trouble 12 = fault	0 = normal 1 = alarm 2 = trouble 3 = fault see note 6	0 = no 4 = yes	0 = no 8 = yes
Entry 1 = EOL + Open		Entry 2 = Short + auto restore + vent zone		

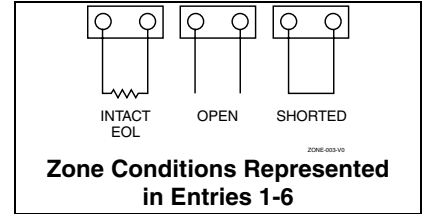

Configurable Zone Type Notes

1. Do not use the “fault delay” option with a configurable zone type if it is set for an entry or exit delay, otherwise unpredictable results may occur.
2. To create an interior type zone, select “respond as interior zone type” (entry 8, interior type = yes), and set zone response to “fault” in entries 3-4 to ensure fault displays; do not set as “normal,” “alarm,” or “trouble.”
3. Do not set fire zones to respond as a “fault” (entries 1-6), otherwise faults will not display unless the [*] key is pressed.
4. RF Zones: The “open” option in entries 1, 3, and 5 is not applicable for RF zones. Use the “intact EOL” option for normal RF zone conditions and “shorted” for off-normal RF zone conditions.

ENTRY 3		ENTRY 4		
Response when armed STAY and zone is:				
Intact EOL RF zone normal	Open RF zone N/A	Shorted RF zn off-normal	Byp. when disarmed	Byp. when armed
0 = normal 1 = alarm 2 = trouble 3 = fault	0 = normal 4 = alarm 8 = trouble 12 = fault	0 = normal 1 = alarm 2 = trouble 3 = fault see note 6	0 = no 4 = yes	0 = no 8 = yes
Entry 3 = EOL + Open		Entry 4 = Short + byp. disarmed + byp. armed		

ENTRY 5		ENTRY 6		
Response when armed AWAY and zone is:				
Intact EOL RF zone normal	Open RF zone N/A	Shorted RF zn off-normal	Dial Delay (see field *50)	Fault Delay (see field *87)
0 = normal 1 = alarm 2 = trouble 3 = fault	0 = normal 4 = alarm 8 = trouble 12 = fault	0 = normal 1 = alarm 2 = trouble 3 = fault see note 6	0 = no 4 = use delay	0 = no 8 = use delay see note 1
Entry 5 = EOL + Open		Entry 6 = Short + dial delay + fault delay		

ENTRY 7		ENTRY 8		
Display Faults	Power Reset/ Verification	Use Entry Delay 1/2	Use Exit Delay	Respond as Interior Type
0 = show alarms when armed & disarmed 1 = don't show alarms when armed (show alarms, trbles, faults when disarmed) 3 = never show any alarms, trbles, faults	0 = no 4 = power reset after fault (with code + OFF) 12 = verification (see zone type 16)	0 = no 1 = delay 1 2 = delay 2	0 = no 4 = use exit delay	0 = no 8 = yes see note 2
Entry 7 = fault display + power reset/verification		Entry 8 = entry delay 1/entry delay 2 + exit delay + interior zone type		

ENTRY 9			ENTRY 10	
Alarm Sounds	Use Bell Timeout	Respond as Fire Zone	Trouble Sounds	Chime when Chime Mode On
0 = none 1 = steady keypad 2 = steady bell and keypad 3 = pulsing bell and keypad	0 = no 4 = yes see fields *32, *33	0 = no 8 = yes see zone type 09; see note 4	0 = none 1 = periodic beep 2 = trouble beeps	0 = no 4 = yes
Entry 9 = alarm sounds + bell timeout + fire zone			Entry 10 = trouble sounds + chime	

Keypad Programming Fields

NOTE: Each keypad must be assigned a unique address. Keypads programmed with the same address will give unpredictable results.

Address 16 is reserved for keypad 1, which is automatically set with all sounds enabled.

FIELD	TITLE and EXPLANATION
*190	Keypad 2 Device Address 17 Select whether or not this keypad is used, and enter the desired sound option for this keypad.
*191	Keypad 3 Device Address 18 Select whether or not this keypad is used, and enter the desired sound option for this keypad.
*192	Keypad 4 Device Address 19 Select whether or not this keypad is used, and enter the desired sound option for this keypad.
*193	Keypad 5 Device Address 20 Select whether or not this keypad is used, and enter the desired sound option for this keypad.
*194	Keypad 6 Device Address 21 Select whether or not this keypad is used, and enter the desired sound option for this keypad.
*195	Keypad 7 Device Address 22 Select whether or not this keypad is used, and enter the desired sound option for this keypad.
*196	Keypad 8 Device Address 23 Select whether or not this keypad is used, and enter the desired sound option for this keypad.
*197	Exit Time Display Interval Select whether or not keypads display the exit time remaining after arming the system, with display updates at the interval selected (i.e. if the exit delay is 30 seconds and “2” is selected in this field, the keypad display refreshes every 2 seconds, displaying 30, 28, 26, 24, etc.). An interval greater than “1” may be necessary for some older keypads to allow users time to enter key presses between display updates.
*199	ECP Fail Display Select the 2-digit or 3-digit ECP Fail display, based on the type of keypads being used. The 3-digit display option displays ECP faults as “1” plus the device address (00-30) of the device causing the fault (e.g., faults on device 07 display as “107”), and is intended for Alpha keypads and/or 3-digit Fixed-Word Display keypads. The 2-digit Fixed-Word Display displays ECP faults for all devices as “91” on 2-digit displays, and “191” on 3-digit or Alpha keypads. It is intended for 2-digit display keypads.

Menu Mode Programming



Zone Programming Overview (*56 and *58 Menu Modes)

Use *56 Zone Programming to program zones, zone types, report codes, enroll 5800 RF Wireless Transmitter serial numbers, and identify the type of loop input device(s). This mode can also be used to enter alpha descriptors for programmed zones; however, we recommend entering descriptors in menu mode *82 (*Alpha Descriptor Programming*) after all zone programming has been completed. *58 Expert Programming Mode offers a faster method of zone programming for those who have had previous experience in programming control panels of this type.

*56 Zone Programming Procedure

Zone Programming involves:

1. Entering the zone number to be programmed;
2. Making appropriate entries at the prompts;
3. Confirming the serial number of wireless transmitter zones.

Start Zone Programming mode by pressing *56 while in Data Programming mode. The following prompts are displayed:

PROMPT	VALID ENTRIES and EXPLANATION
SET TO CONFIRM? 0 = NO 1 = YES	If 1 (Yes) is entered, you will be prompted to confirm each transmitter after entering the serial and loop numbers (at the "XMIT TO CONFIRM" prompt later in this procedure). We recommend that you confirm the programming of every transmitter.
Enter Zn Num. (00 = Quit) 10	Enter the zone number that you wish to program (e.g. zone 10 as shown in the display). wired zones 01-06; wireless zones 09-24; button zones 49-56 Enter a report code for zone 91 to enable addressable device reporting. Enter a report code for zone 92 to enable duress reporting. 95, 96, 99 are emergency (panic) key zones. 00 to quit; [*] to continue
Zn ZT RC In: L 10 00 10 RF: 1	A summary display appears. "IN: L" appears for wireless zones and indicates input type and loop. "HW: RT" appears for hardwire zones and indicates configuration (EOL, NO, NC,) and response time selection. [*] to continue
10 Zone Type Perimeter 03	Each zone must be assigned to a zone type (list below), which defines the way in which the system responds to faults in that zone. Note: If 00 is entered, Delete Zone ? will be displayed. 00 = Not used 07 = 24-Hr Audible 20 = Arm-STAY* 01 = Entry/exit #1 08 = 24-Hr Aux 21 = Arm-AWAY* 02 = Entry/exit #2 09 = Fire 22 = Disarm* 03 = Perimeter 10 = Interior w/Delay 23 = No Alarm Resp* 04 = Interior Follower 12 = Monitor Zone 24 = Silent Burglary 05 = Trouble Day/Alarm Night 14 = Carbon Monoxide 77 = Keypress 06 = 24-Hr Silent 16 = Fire w/Verify 81 = AAV Monitor Zone *5800 button-type transmitters only 90 = Configurable

10 Report Code
1st 01 2nd 00 10

Enter the report code for this zone, which consists of 2 hexadecimal digits, each in turn consisting of 2 numerical digits. For example, for a report code of "10," enter 01 and 00. For Contact ID[®], entering any non-zero entry as the first digit enables the report code for this zone. Refer to the **System Communication** section for information about report codes and formats.
Report code digits: 1-9, #+10 for 0, #+11 for B, #+12 for C, #+13 for D, #+14 for E, #+15 for F 00 to disable; [*] to continue

02 HARDWIRE TYPE
EOL 0

This prompt appears only for zone numbers 01-06.
Enter the desired hardwire type:
0 = EOL; 1 = NC; 2 = NO
[*] to continue

02 Response Time
1

This prompt appears only for hard-wired zones 01-06 (zone 02 is used as an example in display).
Enter the desired response time for this zone:
0 = 10mSec; 1 = 350mSec; 2 = 700mSec; 3 = 1.2 seconds
[*] to continue

10 INPUT TYPE
RF TRANS 3

For wired zones 1-6, the Input Type automatically displays as HW and cannot be edited. All of the RF transmitters have one or more unique factory-assigned input loops (ID codes). Each of the input loops requires its own programming zone (e.g., a 5804's four button inputs require four programming zones). Select the desired input type for the transmitter zone being programmed.
3 = RF (supervised RF transmitter; sends fault, restore, and low-battery signals, and sends periodic check-in signals; transmitter must stay within receiver's range)
4 = UR (unsupervised RF transmitter; sends fault, restore, and low-battery signals, but does not send periodic check-in signals; transmitter may be carried off-premises)
5 = BR (unsupervised button type RF transmitter; sends fault and low battery signals when activated, does not send restore or check-in signals; transmitter may be carried off-premises)
[*] to continue

10 INPUT S/N:	L
A022-4064	1

For wireless transmitters, enroll the serial number and loop number.
1. a. Transmit two open/close sequences. If using a button-type transmitter, press and release the button twice, but wait about 4 seconds before pressing the button the second time.
OR
b. Manually enter the 7-digit serial number printed on the label of the transmitter. Press the [*] key to move to the "L" position, then enter the loop number (see Loop Identification chart on back cover).
If desired, you can press the [C] key to copy the previously enrolled serial number (used when programming a transmitter with several input loops). The cursor moves to the loop number position.
c. To delete an existing serial number, enter 0 in the loop number field. The serial number will change to 0's. If 0 was entered in error, simply re-enter the loop number or press [#], and the serial number will return to the display.
2. Press [*] to continue. The system now checks for a duplicate serial/loop number combination.

10 INPUT S/N	L
A022-4064	1

If the serial/loop number combination is not a duplicate in the system, a display showing the serial number and loop number entry appears.
[*] to continue

XMIT TO CONFIRM
PRESS * TO SKIP

This prompt will only appear if you answered "Yes" at the "SET TO CONFIRM" prompt. The system now enters a confirmation mode so that the operation of the actual programmed input can be confirmed.
Activate the loop input or button that corresponds to this zone.
[*] to continue

Entd A022-4063 1 Rcvd A022-4064 1

If the serial number transmitted does not match the serial number entered, a display similar to the one shown appears. If the loop number does not match, it will also be displayed.
If so, activate the loop input or button on the transmitter once again. If a match is not obtained (i.e., summary display does not appear), press the [#] key twice and then enter (or transmit) the correct serial number.
[*] to continue

Zn ZT RC In: L 10 03 10 RF: 1s

If the serial number transmitted matches the serial number entered, the keypad will beep 3 times and a summary display will appear, showing that zone's programming. An "s" indicates that a transmitter's serial number has been enrolled.
[*] to accept the zone information and continue

PROGRAM ALPHA? 0 = NO 1 = YES 0

If you want to program descriptors for the zone now, enter 1 (yes) and refer to the *82 Descriptor Programming section for procedures.
To program descriptors later, enter 0 (no).
[*] to continue

ENTER ZN NUM. (00 = QUIT) 11

If 0 (No) was entered at the Program Alpha prompt, the system will return you to the ZONE NUMBER prompt. Repeat these steps for each zone in the system.
When all zones have been programmed, enter 00 as the zone number to quit.
[*] to continue

Completing Zone Programming

When you have finished programming all zones, test each zone using the system's TEST mode. **Do not use the Transmitter ID Sniffer Mode for checking wireless transmitting devices**, as it will only check for transmission of one zone on a particular transmitter, NOT the zones assigned to each additional loop.

NOTE: Following the successful enrollment of each wireless device, note the device serial number in the appropriate column on the ENROLLED TRANSMITTERS worksheet in the Programming Form; then enter the other information (zone number, zone type, loop number, etc.) relevant to that device.

*58 Expert Programming Mode Procedures

This method is designed for use by installers with previous experience in programming ADEMCO control panels. This mode is also used to program wireless keys using pre-defined templates.

Start Expert Programming mode by pressing *58 while in Data Programming mode. The following prompts are displayed:

PROMPT	VALID ENTRIES	EXPLANATION
SET TO CONFIRM? 0 = NO 1 = YES		We recommend that you select "yes" to confirm the programming of every transmitter. If selected, a prompt appears after entering the serial and loop numbers to confirm each transmitter)
Zn ZT RC HW: RT 01 09 10 EL 1		A summary screen will appear, showing zone 1's currently programmed values. Enter the zone number being programmed, then press [*]. In this example, zone 10 is being entered
Zn ZT RC IN: L 10 - - -: -		(see Zone Number prompt in *56 Menu Mode for zone numbers). [D] = for assigning wireless key programming templates (see Wireless Key Programming Templates section in i/i); lets you choose from a series of preset templates for easy programming of wireless key zones 00 = quit (when all zones have been programmed, press "00" to quit this menu mode) [*] to continue

Zn	ZT	RC	IN:	L
10	00	10	RF	1

A summary screen with the selected zone's current programming appears. Begin programming zone information as follows:
 Enter Zone Type (ZT; see Zone Types listed in *56 Menu Mode "Zone Type" prompt), Report Code (RC), and Input Device Type (IN)* sequentially (Loop Number (L) is entered at the next prompt).

- Use the [A] (Advance) and [B] (Back) keys on the keypad to move the cursor within the screen.
- Use the [C] key to copy the previous zones attributes.

* If HW (hardwired) or AW (Auxiliary) is entered for Input Device Type, the display will be similar to the prompt shown, except that HW or AW will be under "IN".

Press [*] to save the programming and continue. If needed, press the [#] key to back up without saving.
 For wireless devices (input types RF, UR, BR), continue to the serial number/loop number prompt.
 For wired devices, return to the initial summary screen prompt to begin programming the next zone.

10	INPUT S/N:	L
	AXXX-XXX	-

Manually enter the serial number (found on the transmitter label), by typing digits in the "X" locations, using the [A] (advance) or [B] (back) keys as required.

Zn	ZTP	RC	In	L
10	03	1	10	RF:1s

OR
 Transmit two open/close sequences. If using a button-type transmitter, press and release the button twice, but wait about 4 seconds before pressing the button the second time.
 If you want to copy the previous zone's serial number, press the [C] key.
 Press [*] to advance to the loop number, then enter loop number.
 Press [*] to accept the existing serial and loop number and continue to the "Confirm" prompt described in *56 Menu mode above.
 If necessary, press [#] to back up and re-enter or edit the serial number.
 If the serial number transmitted matches the serial number entered, the keypad will beep 3 times and a summary display will appear, showing the programmed information for that zone.
 Press [*] to begin programming the next zone. See first "Summary Screen" prompt paragraph.

Wireless Key Programming Templates

This procedure programs the wireless keys, **but a key is not active until it is assigned to a user number** (see *System Operation* section, assigning attributes command).

If the D key was previously pressed (from *58 Menu mode) to enter and duplicate 5804 and/or 5804BD wireless keys, the following screens appear.

TEMPLATE ?		
1-6		1

Enter desired template number 1-6 (see chart).
 Press [#] if you want to return to *58 Menu mode Summary Screen.
 If necessary, press [#] to back up and re-enter template number.
 Press [*] to continue to template display.

L	01	02	03	04
T	23	22	21	23

The selected template is displayed.
 Top line of display represents loop numbers, bottom line represents zone type assigned for each loop.
 Press [*] to accept template and continue.

ENTER START ZONE	
00 = QUIT	36

The system will search for the highest available consecutive 4-zone group (the four zones in the case of the 5804 and 5804BD), and display the lowest zone number of the group.
 If you want to start at a different zone, enter the zone desired, and press [*]. If that zone number is displayed, the system has the required number of consecutive zones available, beginning with the zone you entered. If not, the system will again display a suggested zone that can be used.
 If the required number of consecutive zones is not available at all, the system will display "00".
 Press [*] to accept and continue.

INPUT S/N	L
AXXX-XXXX	-

Manually enter the serial number printed on the label for the wireless key or press and release the button to transmit its serial number.

Press [*] to accept the serial number. The system will check for duplicate. If necessary, press the [#] key to back up without saving, and re-enter the serial number. Use the [A] key to move forward within the screen, and the [B] key to move backward.

XMIT TO CONFIRM
PRESS * TO SKIP

If “Yes” was entered at the SET TO CONFIRM? prompt (first prompt following entry into the *58 Expert Programming Mode), this display appears.

Confirm serial and loop numbers by activating the wireless key. Refer to the “Confirm” prompt described in *56 Menu mode above for more information on confirming the serial number.

If the serial number transmitted matches the serial number entered, the keypad will beep 3 times and will return you to the ENTER START ZONE NUMBER prompt to enter the starting zone for the next wireless key.

IMPORTANT: When confirmed, the key is not active until it is assigned to a user number (using the assigning attributes command, attribute “4”). See System Operation section. [*] to skip confirm.

Wireless Key Predefined Default Templates

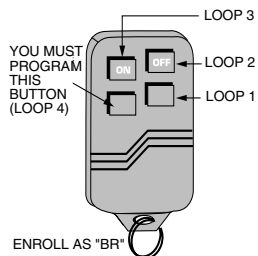

Note:
These transmitters are not intended for use in UL installations.

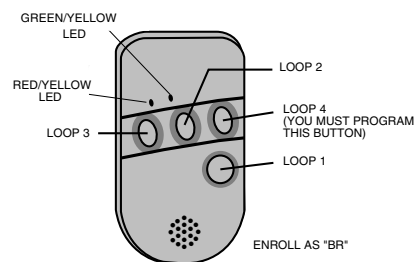

5804 Wireless Key Transmitter

5804BD 2-Way Wireless Key Transmitter

For 5804				For 5804BD			
TEMPLATE 1	Loop	Function	Zone Type	TEMPLATE 4	Loop	Function	Zone Type
	1	No Response	23		1	No Response	23
	2	Disarm	22		2	No Response	23
	3	Arm Away	21		3	Arm Away	21
	4	No Response	23		4	Disarm	22
TEMPLATE 2	Loop	Function	Zone Type	TEMPLATE 5	Loop	Function	Zone Type
	1	No Response	23		1	No Response	23
	2	Disarm	22		2	Arm Stay	20
	3	Arm Away	21		3	Arm Away	21
	4	Arm Stay	20		4	Disarm	22
TEMPLATE 3	Loop	Function	Zone Type	TEMPLATE 6	Loop	Function	Zone Type
	1	24-hour audible	7		1	24-hour audible	7
	2	Disarm	22		2	Arm Stay	20
	3	Arm Away	21		3	Arm Away	21
	4	Arm Stay	20		4	Disarm	22

Output Device Programming Overview (*79/*80 Menu Mode)

Output Devices: The system supports up to 4 relays plus 2 built-in trigger outputs. These “output devices” are assigned to system-wide output numbers (01-04, 17, 18). Relays are identified by the relay module’s device address and the relay position on the module (i.e. the physical relay number, 1-4, on the module). Built-in triggers are identified by the output number, 17 for trigger 1 and/or 18 for trigger 2. Use *79 Menu Mode to assign output numbers and map them to device addresses.

Output Functions: The system also provides up to 12 installer-defined output functions, which can be assigned to any of the physical outputs. Therefore, the action of any one of the outputs can be based on as many of these functions as desired. This lets a single relay perform many functions. Use *80 Menu Mode to define output functions.



Relays are not recommended for life safety applications.

MENU NAVIGATION NOTE: For *79 and *80 menus, press the [*] key to accept an entry and advance to the next prompt. Use the [#] key to go back to the last question if needed (to check or change an entry). Press [*] to go forward again.

Output Device programming involves:

1. Use *79 Menu Mode to assign module and output numbers and map them to device addresses.
NOTE: You must map output devices using *79 Menu Mode **before** you can use *80 menu Mode.
2. Use *80 Menu Mode to create output definitions, which control the output devices.

*79 Menu Mode: Output Device Mapping

Use this menu to assign the Relay Module device address and specific relay numbers. The system is based on predefined module addresses. The address for the 4204 is 12. Refer to the “Module Address” prompt on the next page and set the module’s address (via module DIP switches) accordingly.

Start Output Device Mapping by pressing *79 while in Data Programming Mode. The following prompts are displayed:

*79 Menu Mode

PROMPT	VALID ENTRIES and EXPLANATION
ENTER OUTPUT NO. 00 = QUIT xx	Enter the logical (or reference) relay number as used in the system. 01-04 = relays; 17-18 = on-board triggers (can be programmed for inverted output; see next prompt). Use the worksheet on the Programming Form (printed separately) to organize device numbers. [*] to continue
17 OUT NORM LOW 0 = NO 1 = YES 0	This prompt appears only for triggers 17 and 18. 0 = no (standard default); sets the trigger output level normally high 1 = yes; sets the trigger output normally low (can be used for resetting 4-wire smoke detectors by connecting trigger wire to the negative power terminal of the smoke detector, selecting 1 at this prompt, and setting as zone type 54, fire zone reset, in *80 Menu mode) [*] to return to Output Number prompt (use *80 Menu mode to program the function of the trigger)
XX OUTPUT TYPE DELETE? 0	Enable or delete this output. 0 = delete this output number; 1 = enable output [*] to continue
XX MODULE ADDR 07-15 yy	Enter the module’s predefined address “12” (set the module’s DIP switches to “12”). [*] to continue
XX REL POSITION 1-4 zz	Enter the actual (or physical) relay number, 1-4, with respect to the Relay Module upon which it is located. [*] to return to the Output Number prompt for programming the next device

*80 Menu Mode: Defining Output Functions

Use this mode to program output function definitions (up to 12 functions) that provide automated control of any of the output devices, based on events occurring on individual zones or zones with certain zone types. Each output definition is identified by an output function number, and includes the following components:

Output Definition Components

Component	Description
Output Function No.	A reference number that defines an output's characteristics.
Activated By	Determines whether the initiating event occurs on a zone, a zone list, or a zone type.
Event	Event that triggers the output action. Can be an event occurring on a specific zone number or a zone list, or a specific zone type.
Output Action	Defines the action of the relay when the defined event occurs. Can close for 2 seconds, stay closed until reset, continuously pulse (1-second close-open-close-open, etc.), toggle the device state, or activate for a defined duration (set in data field *177).
Output No.	Assigns this function to a specific output number (defined in *79 Menu Mode). This is the output number that will perform this function upon the triggering event. Note that each defined function is associated with only one output number. This means that if more than one output device needs to perform this particular function, you need to define another output function number with the same attributes, but assign the appropriate output number. (i.e. output devices can be assigned more than one function number, but each function number can only be assigned a single output number.

For example, if you want to pulse a strobe light upon fire alarms on zone 4 using a relay mapped to output number 2 (as programmed in *79 Menu Mode), program the following in *80 Menu Mode:

Prompt **Entry**
 Output Funct. # = 01 (assuming this is the first output function)
 Activated By: = 3 (zone number)
 Enter Zn No. = 04 (requires 2-digit zone numbers)
 Output Action = 3 (continuous pulse)
 Output Number = 02 (device mapped in *79 Menu Mode)

Start Output Definition mode by pressing *80 while in Data Programming mode.

*80 Menu Mode

PROMPT	VALID ENTRIES and EXPLANATION
<div style="border: 1px solid black; padding: 5px;"> Output Funct. # (00 = Quit) 01 </div>	Enter the output function number to be defined 01-12 = output function number [*] to continue; 00 = exit
<div style="border: 1px solid black; padding: 5px;"> 01 A E Trig ?00 0 0 - ZL=1 </div>	This screen displays a summary of the current output programming A = Output Action; E = Triggering event; Trig = Trigger type Question mark indicates the device shown has not been mapped. Use *79 Menu mode to map the device. [*] to continue
<div style="border: 1px solid black; padding: 5px;"> 01 Activated By: Zone List </div>	Select where the initiating event for this output definition is to occur. 0 = delete (deletes the output function and any previous programming) <div style="border: 1px solid black; padding: 5px; margin: 10px 0;"> Delete? 0 = NO, 1 = YES </div> To delete this output definition, press 1. If you do not want to delete this output, press 0. 1 = zone list (go to "A" prompt); 2 = zone type (go to "B" prompt); 3 = zone number (go to "C" prompt) [*] to continue

"A"

01 Zn List	1
------------	---

If zone list was selected, this screen appears. Otherwise skip to the next prompt.
 Enter the desired zone list number associated with this output number:
 01-08 = zone list (Do not use pager zone list 09 in output definitions)
 Enter the zone list event that will activate this output:

Enter Event	1
Alarm	1

0 = restore; 1 = alarm;
 2 = fault; 3 = trouble

NOTE: For alarm, fault, and trouble, an event on ANY zone in the list activates the output, but ALL zones in the list must be restored before the output is restored.
 Press [*] to continue and skip to the "Output Action" prompt.

"B"

01 Enter Zn type	
Perimeter	03

If zone type was selected, this screen appears. Otherwise skip to the next prompt.
 Enter the desired zone type for this output number.

CHOICES FOR ZONE TYPES:

- | | | |
|------------------------|------------------------------|--------------------------|
| 00 = Not Used | 05 = Trouble Day/Alarm Night | 12 = Monitor Zone |
| 01 = Ent/Exit #1 | 06 = 24 Hr Silent | 14 = Carbon Monoxide |
| 02 = Ent/Exit #2 | 07 = 24 Hr Audible | 16 = Fire w/verification |
| 03 = Perimeter | 08 = 24 Hr Aux | 23 = No Alarm Response |
| 04 = Interior Follower | 09 = Fire | 24 = Silent Burglary |
| | 10 = Interior w/Delay | 77 = keyswitch zone |
| | | 81 = AAV Monitor Zone |
| | | 90 = Configurable |

CHOICES FOR SYSTEM OPERATION:

- | | | |
|--------------------------|-------------------------|--------------------------|
| 20 = Arming-Stay | 36 = At Bell Timeout*** | 52 = Kissoff |
| 21 = Arming-Away | 38 = Chime | 54 = Fire Zone Reset |
| 22 = Disarming | 39 = Any Fire Alarm | 58 = Duress |
| 31 = End of Exit Time | 40 = Bypassing | 60 = AAV |
| 32 = Start of Entry Time | 41 = AC Power Failure | 66 = Function Key† |
| 33 = Any Burglary Alarm | 42 = System Battery Low | 67 = Bell Fail |
| | 43 = Comm. Failure | 68 = Telco line cut |
| | | 78 = keyswitch red LED |
| | | 79 = keyswitch green LED |

*** Or at Disarming, whichever occurs earlier.

† Use *57 Menu Mode to assign the function key (function "07").

Note: In normal operation mode:

Code + # + 7 + NN Key Entry **starts** Device NN.

Code + # + 8 + NN Key Entry **stops** Device NN.

Press [*] to continue and skip to the "Output Action" prompt.

"C"

01 Enter Zn No.	
	12

If zone number was selected, this screen appears.
 Enter the desired zone number associated with this output number.
 Press [*] to continue.
 Enter the zone event that will activate this output:

01 Enter Event	
Restore	0

0 = restore; 1 = alarm/fault/trouble

Press [*] to continue to the "Output Action" prompt

01 Output Action	
Close for 2 sec	1

Enter the desired device action as listed below.

- | | |
|---|--------------------------------------|
| 0 = off | 4 = Change Device State |
| 1 = Close for 2 seconds | 5 = Duration 1 (see data field *177) |
| 2 = Close and Stay Closed | 6 = Duration 2 (see data field *177) |
| 3 = Continuous Pulse on & off (1 sec ON, 1 sec OFF) | |

Press [*] to continue.

Enter Output No.	
R02	02

Enter the device output number (programmed in *79 Menu Mode) you want associated with this output.

01-04 = output no.
 17-18 = on-board triggers

Press [*] to continue.

02 A E P TRIG	
R02 1 1 3 ZL=1	

A summary screen appears showing the programmed settings.

Press [*] to return to output function number prompt.

Zone List Overview (*81 Menu Mode)

Zone lists let you group individual zones for use with certain system actions. The following table shows the available zone lists and their purposes:

List No.	Used for...
1, 2	general purpose
3	chime-by-zone
4	cross zones
5	night stay zones
6, 7, 8	general purpose
9	zones that activate pager 1

Zone List Programming

Zone List programming involves:

1. Selecting an appropriate zone list number;
2. Adding the desired zone numbers to be included in that list.

Start Zone List Program Mode by pressing *81 while in Data Programming mode. The following prompts are displayed:

*81 Menu Mode

PROMPT	VALID ENTRIES	EXPLANATION
<div style="border: 1px solid black; padding: 2px;"> Zone List No. (00 = Quit) 01 </div>	01-09 = zone list number [*] to continue	Enter the Zone List Number to program (or 00 to end these entries).
<div style="border: 1px solid black; padding: 2px;"> 01 Enter Zn Num. (00 = Quit) 00 </div>	01-06 = wired zones; 09-24 = wireless zones; 49-56 = button zones 91 = addr. device report enable (Enter a report code for zone 91 to enable addressable device reporting. 92 = duress report enable (Enter a report code for zone 92 to enable duress reporting) 95, 96, 99 =emergency zones 00 to continue IMPORTANT: Do not include fire zones in zone lists that are used to STOP device actions.	Enter each zone number followed by [*] to add each zone to the zone list.
<div style="border: 1px solid black; padding: 2px;"> 01 Del Zn List? 0 = No 1 = Yes 0 </div>	To delete the zone list, enter 1. All zones in the zone list will be deleted automatically and the system returns to the Zone List No. prompt. To save the zone list, enter 0. [*] to continue	
<div style="border: 1px solid black; padding: 2px;"> 01 Delete Zone? 0 = No 1 = Yes 0 </div>	To save the entire zone list, enter 0 and the system returns to the Zone List No. prompt. To delete a zone or zones in a zone list enter 1 to continue. [*] to continue	
<div style="border: 1px solid black; padding: 2px;"> 01 Zn to Delete? (00 = Quit) 00 </div>	01-64 = zones to be deleted from list 00 when done to return to the Zone List No. prompt	Enter each zone to be deleted from the list followed by [*] to accept each zone.

NOTES:

- Any list may include any or all of the system's zone numbers.
- A zone list can be assigned to more than one output relay.
- When creating zone list 4 for cross zoning, include only zones assigned to zone types 3, 4, or 5. Do not include zones that have delays (entry/exit zones, interior w/delay) or 24-hour zones, as these zone types may produce unpredictable operation and may not function as intended.

Function Key Programming Overview (*57 Menu Mode)

The system provides the ability to program each of the four keypad function keys to perform one of 12 system operations. The end user can then activate the function by simply pressing and holding the programmed key for 2 seconds. Typical functions (listed below) include single-button arming, turning lights on/off, or single-button paging.

Programming Function Keys

Function key programming involves:

1. Assigning the function key number;
2. Selecting the desired function for that key.

Start Function Key Programming mode by pressing *57 while in Data Programming mode. The following prompts are displayed:

PROMPT	VALID ENTRIES	EXPLANATION
<div style="border: 1px solid black; padding: 5px; width: fit-content;"> Press Key to Pgm 0 = Quit 0 </div>	Press the desired function key, A-D. NOTE: A key programmed as a function key is no longer available to be used as an end-user macro key or panic key. [*] to continue	

<div style="border: 1px solid black; padding: 5px; width: fit-content;"> Key "A" Func Zone 95 00 </div>	Enter the desired function for this key: 00 = For the Function key selected, the function will be as follows (system default): If A selected = Zone 95 (emergency key, same as [1] [*] pair) If B selected = Zone 99 (emergency key, same as [*] [#] pair) If C selected = Zone 96 (emergency key, same as [3] [#] pair) If D selected = Single-button paging 01 = Single-button paging (sends a 999-9999 message to pager) 02 = Display time 03 = Arm AWAY (reports as User 00 if closing reports are enabled) 04 = Arm STAY (reports as User 00 if closing reports are enabled) 05 = Arm NIGHT-STAY (reports as User 00 if closing reports are enabled) 06 = Step Arming (arms STAY, then NIGHT-STAY, then AWAY) 07 = Output Device Command (for device programmed as system operation type 66 in *80 Menu Mode) 08 = Communication Test (sends Contact ID code 601) 09 = Macro Key (defined by [#] [6] [6] command) [*] to continue; returns to key number prompt with the next function key letter displayed.
---	--

About Descriptor Programming Overview (*82 Menu Mode)

The system lets you assign zone descriptors for protection zones, keypad panics, and RF receiver supervision faults. Each description can be composed of a combination of words (up to 3) selected from a vocabulary of 196 words stored in memory (see a following page). In addition, up to 10 installer-defined words can be added to those already in memory. Thus, when an alarm or trouble occurs in a zone, an appropriate description for that zone's location can be displayed at the keypad. Zone descriptors are recommended for systems using Alpha display keypads, and are necessary if a Phone Module is used.

NOTE: You can enter zone descriptors when the zone is being defined in *56 Menu mode, but we recommend you do it using *82 Menu mode.

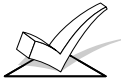

If using an FA4285 or FA4286VIP Phone Module, select from those words in the Alpha Vocabulary List shown in **boldface type**. The phone module will not provide annunciation of the other words.

If an FA4285/FA4286 Phone Module is added to an existing system, the Alpha descriptors presently in the system should be reprogrammed, selecting from those words shown in **boldface type** in the Alpha Vocabulary List. The phone module will not provide annunciation of any other words.

Programming Zone Descriptors (Menu mode *82)

Descriptor programming involves:

1. Entering index numbers for up to three words from the vocabulary list for each descriptor;
2. Entering up to ten 10-digit custom words, if desired, which can then be used in descriptors.

When defining descriptors:

- Pressing the [6] key accepts the entered index number and moves the cursor to the next position.
- Pressing the [8] key saves the entered descriptor and moves to the next descriptor.

Start Zone Descriptor Programming mode by pressing *82 while in Data Programming mode.

PROMPT	VALID ENTRIES and EXPLANATION
<div style="border: 1px solid black; padding: 5px;"> Program Alpha ? 0=No, 1=Yes 0 </div>	Press 1 to program descriptors. 0 = exit this mode
<div style="border: 1px solid black; padding: 5px;"> Custom Words ? 0=No, 1=Yes 00 </div>	To program standard alpha descriptors from the fixed vocabulary, press 0. The system will then automatically display the descriptor for zone 1. To define custom words (described below in "Adding Custom Words" section), press 1.
<div style="border: 1px solid black; padding: 5px;"> * ZN 01 </div>	Summary screen of zone 1 descriptor (if programmed) is displayed. Press [*] to start blinking cursor at zone number, then enter the zone number for which the descriptor is being programmed. <ul style="list-style-type: none"> • If a descriptor is programmed for that zone, it is displayed. • To delete or change a previously programmed descriptor, press [*] plus the same zone number. This will clear that descriptor and move the cursor to the first word position. • If you do not wish to change the existing descriptor, enter [*] plus the next zone number for which you wish to enter (or check) a descriptor. A summary display for that zone will appear. You must then press [*] plus the same zone number again to program a descriptor for that zone. • If no descriptor has been programmed for that zone, the cursor moves to first word position.
<div style="border: 1px solid black; padding: 5px;"> * ZN 01 <input type="text"/> </div>	Select first word of descriptor: Press [#] plus the 3-digit index number for the first word from the Alpha Vocabulary List. See index for entries. Example: The descriptor that we wish to enter for zone 1 is BACK DOOR. From the list, BACK = 013. Therefore, you would enter #013. If you enter the wrong word, simply press [#] plus the 3-digit number for the desired word.
<div style="border: 1px solid black; padding: 5px;"> * ZN 01 BACK <input type="text"/> </div>	Save first word of descriptor: 6 = save word and go to next word in this descriptor 8 = save word and end descriptor if this is the only word used for the descriptor - go to summary screen

<p>* ZN 01 BACK <input type="text" value="D"/>OOR</p>	<p>Enter the 3-digit number for the next word. In the example, the word is DOOR, whose number is "057." See index for entries. [*] to continue</p>
<p>* ZN 01 BACK DOOR <input type="text" value=""/></p>	<p>Save second word of descriptor: 6 = save word and go to next word in this descriptor 8 = save word and end descriptor if this is the only word of the descriptor - go to summary screen The two words in the example have now been entered. Note, however, that up to three words may be entered (provided the number of characters will fit on the screen).</p>
<p>* ZN 01 BACK DOOR</p>	<p>Summary Screen The blinking cursor will disappear, indicating that the word(s) are saved in memory. To enter a descriptor for the next zone, press [*] plus the desired zone number (e.g., *02). The summary display for that zone will appear. Repeat the previous steps to enter the descriptor for the next zone. To exit the Alpha descriptor mode, enter zone "00" at the summary display, which returns you to the Program Alpha prompt. Enter "0" at that prompt to exit.</p>

Adding Custom Words (will not be annunciated by FA4285/FA4286 Phone Module)

You can add up to 10 installer-defined words to the built-in vocabulary, which can then be used when programming zone descriptors. Each of the 10 words can actually consist of a word string of one or more words, but no more than *ten* characters can be used for each word or word string.

PROMPT	VALID ENTRIES and EXPLANATION
<p>Program Alpha ? 0=No, 1=Yes 00</p>	<p>The "Program Alpha ?" prompt will appear. 1 = program zone descriptors and/or partition descriptors or reminder words; 0 = exit [*] to continue</p>
<p>Custom Words ? 0=No, 1=Yes 0</p>	<p>Custom words let you assign partition descriptors and "reminder" words (for Scheduling mode, event "10"). NOTE: Do not assign reminder words if using fixed-word keypads. 1 = yes, program partition descriptors or reminder words 0 = no, go to zone descriptors (see above) If "1" selected, enter the 2-digit custom word number (01-10) to be programmed, corresponding to index numbers 245 - 254 respectively (for example, if you are creating the first custom word or word-string, enter 01, for the second, enter 02, etc.). A cursor will now appear at the beginning of the second line.</p>
<p>Custom? 00</p>	<p>08-10 = "reminder" words used with scheduling mode 11 = partition 1 descriptor; 12 = part. 2 descriptor; 13 = common</p>
<p>Custom? 01</p>	<p>A cursor appears at the beginning of the second line. Special Keys:[6] = accept character and move cursor to next position to right [4] = move cursor to left [8] = save custom word</p> <ol style="list-style-type: none"> 1. Refer to the Character Chart. Press [#], followed by the two-digit entry for the first letter you want to display (e.g., # 6 5 for "A"). Press [6] to accept the character and move the cursor to the right, in position for the next character. 2. Repeat Step 1 to enter the next characters until the desired custom word is entered. You can use the [4] key to move the cursor to the left, if necessary. Each custom word can be a maximum of 10 characters. 3. When done, press the [8] key to save the custom word and return to the "Custom ?" prompt. 4. Repeat steps 1-3 to enter other custom words. To change a custom word, simply overwrite it. To exit, enter "00," which returns you to the Program Alpha prompt. Enter "0" at that prompt to exit. <p>Once Custom words are programmedm they can be used in a descriptor in the same way the built-in vocabulary words are used.</p>

ALPHA VOCABULARY LIST
(For Entering Zone Descriptors)

000 (Word Space)	• 059 DOWN	108 LEVEL	• 162 ROOM *	• 219 WING
- A -	• 060 DOWNSTAIRS	• 109 LIBRARY *	163 ROOF	220 WIRELESS
• 001 AIR	061 DRAWER	• 110 LIGHT	- S -	- X -
• 002 ALARM *	• 062 DRIVEWAY	111 LINE	164 SAFE	222 XMITTER
004 ALLEY	• 064 DUCT	• 113 LIVING *	165 SCREEN	- Y -
005 AMBUSH	- E -	• 114 LOADING	166 SENSOR	223 YARD
• 006 AREA	• 065 EAST	115 LOCK	• 167 SERVICE	- Z -
• 007 APARTMENT	066 ELECTRIC	116 LOOP	• 168 SHED *	224 ZONE (No.)
• 009 ATTIC *	067 EMERGENCY	117 LOW	169 SHOCK	• 225 ZONE *
010 AUDIO	*	• 118 LOWER	• 170 SHOP *	• 226 0
- B -	068 ENTRY	- M -	171 SHORT	• 227 1
• 012 BABY *	• 069 EQUIPMENT	• 119 MACHINE	• 173 SIDE *	• 228 1ST *
• 013 BACK *	• 071 EXIT *	121 MAIDS	174 SKYLIGHT	• 229 2
• 014 BAR	072 EXTERIOR	122 MAIN *	175 SLIDING *	• 230 2ND *
• 016 BASEMENT *	- F -	• 123 MASTER *	• 176 SMOKE *	• 231 3
• 017 BATHROOM *	• 073 FACTORY	• 125 MEDICAL *	• 178 SONS	• 232 3RD *
• 018 BED	075 FAMILY	126 MEDICINE	• 179 SOUTH	• 233 4
• 019 BEDROOM *	• 076 FATHERS	128 MONEY	180 SPRINKLER	• 234 4TH
020 BELL	• 077 FENCE	129 MONITOR	• 182 STATION	• 235 5
• 021 BLOWER	• 079 FIRE *	• 130 MOTHERS	184 STORE	• 236 5TH
• 022 BOILER	• 080 FLOOR *	• 131 MOTION *	• 185 STORAGE *	• 237 6
023 BOTTOM	081 FLOW	132 MOTOR	186 STORY	• 238 6TH
025 BREAK	082 FOIL	- N -	190 SUPERVISED	• 239 7
• 026 BUILDING	• 083 FOYER	• 134 NORTH	*	• 240 7TH
- C -	084 FREEZER	135 NURSERY	191 SUPERVISION	• 241 8
028 CABINET	• 085 FRONT *	- O -	192 SWIMMING	• 242 8TH
• 029 CALL	- G -	• 136 OFFICE *	193 SWITCH	• 243 9
030 CAMERA	• 089 GARAGE *	• 138 OPEN *	- T -	• 244 9TH
031 CAR	• 090 GAS	139 OPENING	194 TAMPER	245 Custom Word #1
033 CASH	091 GATE	• 140 OUTSIDE	196 TELCO	246 Custom Word #2
034 CCTV	• 092 GLASS	142 OVERHEAD	197 TELEPHONE	247 Custom Word #3
035 CEILING	093 GUEST	- P -	• 199 TEMPERATURE	248 Custom Word #4
036 CELLAR	094 GUN	143 PAINTING	200 THERMOSTAT	249 Custom Word #5
• 037 CENTRAL	- H -	• 144 PANIC *	• 201 TOOL	250 Custom Word #6
038 CIRCUIT	• 095 HALL *	145 PASSIVE	202 TRANSMITTER	251 Custom Word #7
• 040 CLOSED *	• 096 HEAT	• 146 PATIO *	- U -	252 Custom Word #8
• 046 COMPUTER	098 HOLDUP	147 PERIMETER	• 205 UP	253 Custom Word #9
047 CONTACT	099 HOUSE	• 148 PHONE	• 206 UPPER	254 Custom Word #10
- D -	100 INFRARED	150 POINT	• 207 UPSTAIRS *	
• 048 DAUGHTERS	• 101 INSIDE *	151 POLICE *	• 208 UTILITY *	
049 DELAYED	102 INTERIOR	152 POOL *	- V -	NOTE: Custom words
• 050 DEN *	103 INTRUSION	• 153 POWER	209 VALVE	8, 9, 10 are "reminder
• 052 DETECTOR *	- J -	- R -	210 VAULT	words" that can be
• 053 DINING *	104 JEWELRY	155 RADIO	212 VOLTAGE	programmed to display
054	- K -	157 RECREATION	- W -	using Scheduling
DISCRIMINATOR	-	159	213 WALL	Mode.
055 DISPLAY	L -	REFRIGERATION	214 WAREHOUSE	
• 057 DOOR *	• 106 LAUNDRY *	160 RF	• 216 WEST	
	• 107 LEFT	• 161 RIGHT	• 217 WINDOW *	

Note: Bulleted (•) words in **boldface type** are those that are also available for use by the FA4285/FA4286 Phone Module. If using a phone module, and words other than these are selected for Alpha descriptors, the phone module will not provide annunciation of those words.

Italicized words followed by an asterisk indicate those words supported by the FA560VKP Voice Keypad.

CHARACTER (ASCII) CHART
(For Adding Custom Words)

32 (space)	42 *	52 4	62 >	72 H	82 R
33 !	43 +	53 5	63 ?	73 I	83 S
34 "	44 ,	54 6	64 @	74 J	84 T
35 #	45 -	55 7	65 A	75 K	85 U
36 \$	46 .	56 8	66 B	76 L	86 V
37 %	47 /	57 9	67 C	77 M	87 W
38 &	48 0	58 :	68 D	78 N	88 X
39 '	49 1	59 ;	69 E	79 O	89 Y
40 (50 2	60 <	70 F	80 P	90 Z
41)	51 3	61 =	71 G	81 Q	

Programming Installer and User Schedules

The system provides 2 schedules (one for the installer, one for the end user), which can be used to control 11 types of system events at pre-defined times.

Start Scheduling mode by entering installer code + [#] + [6] [4] while in normal operating mode.

NOTE: The master code can only access schedules 01 and events 00-07.

PROMPT	VALID ENTRIES and EXPLANATION
<div style="border: 1px solid black; padding: 5px;"> ENTER SCHED NO. 00=QUIT 00 </div>	Enter the desired schedule number. 01 = end-user schedule; 02 = installer-only schedule; 00 = exit scheduling mode [*] to continue
<div style="border: 1px solid black; padding: 5px;"> ENTER EVENT CLEAR EVENT 00 </div> <div style="border: 1px solid black; padding: 5px; margin-top: 10px;"> NOTE: Events 07 and 10 cause the keypad to beep every 30 seconds when messages are displayed. Stop the beeps by user code + OFF. </div>	Enter the desired event number for event you want to occur at a specified time. Events 10-11 are reserved for the installer only. 00 = clear event 01 = Relay On/Off 02 = User Access 03 = Latch Key Report to Pager (sent to all pagers; message sent is 777-7777; user must be enabled for paging; see User Attributes in System Operation section) 04 = Forced Stay Arming (forced bypass is automatically enabled regardless of setting in field *23) 05 = Forced Away Arming (forced bypass is automatically enabled regardless of setting in field *23) 06 = Auto Disarm 07 = Display "Reminder" 10 = Display custom words (system displays custom words 8, 9, and 10 at defined time; can be used as installer's reminder message to the end user) 11 = Periodic Test Report (see key commands in Testing the System section to quickly set periodic test reporting intervals) [*] to continue
<div style="border: 1px solid black; padding: 5px;"> DEVICE NUMBER XX </div>	This prompt appears if event "1" (relay on/off) was selected, otherwise it is skipped. Enter the physical device number as programmed in *79 Menu Mode. 01-04 = device number; 17, 18 = built-in triggers 1 and 2 respectively [*] to continue to the "Start" prompt

<pre>GROUP NUMBER X</pre>	<p>This prompt appears if event "2" (user access) was selected. Otherwise it is skipped. 1-8 = group number [*] to continue to the "Start" prompt</p>
<pre>START SMTWTFS HH MMAM 0010000</pre>	<p>Enter the event's start time and days of the week to occur. 01-12 = hour; 00-59 = minute; 0 = AM; 1 = PM Days = position the cursor under the desired days using the [*] key to move forward, then press "1" to select the desired day(s) [*] to continue</p>
<pre>START SMTWTFS HH MMAM 0010000</pre>	<p>Enter the event's stop time and days of the week to occur. This entry applies only to the following events: 1 (relay on/off); 2 (user access); 3 (latch key report) 01-12 = hour; 00-59 = minute; 0 = AM; 1 = PM Days = position the cursor under the desired days using the [*] key to move forward, then press "1" to select the desired day(s) [*] to continue</p>
<pre>REPEAT OPTION 0-4 X</pre>	<p>Enter the desired repeat option for this schedule. e.g., To make a schedule that happens everyday you would select all days with a repeat count of 1. To make a schedule that runs for one week then stops, select everyday with a repeat count of 0. 0 = do not repeat; 1 = repeat schedule weekly; 2 = repeat schedule biweekly (every other week) 3 = repeat every 3rd week; 4 = repeat every 4th week [*] to continue</p>
<pre>RANDOMIZE 0=NO 1=YES X</pre>	<p>Select whether you want this schedule to start and stop at random times. If selected, the scheduled start and stop times will vary within 60 minutes of the "hour" time. For example, if a schedule is set to start at 6:15pm, it will do so the first time 6:15pm arrives, but on subsequent days it will start anytime between 6:00 and 6:59 p.m. [*] to continue</p>

NOTE: Do not use the random option if the start and stop times are within the same "hour" setting, otherwise unpredictable results may occur (e.g., the randomized stop time may occur before the start time).

System Communication and Operation

System Communication Overview

This system accommodates several formats for reporting alarms and other system conditions to the Central Station. The process of a successful transmission consists of both the method of communication between the control panel and the Central Station receiver; and the actual way the information is sent and displayed at the Central Station.

When the panel calls the Central Station receiver, it waits to hear a “handshake” frequency from the receiver to confirm that the receiver is on-line and ready to receive its message. Once the panel hears the handshake it is programmed to listen for, it sends its message. The panel then waits for a “kissoff” frequency from the receiver acknowledging that the message was received and understood.

If the handshake frequency is not given or is not understood by the panel, the panel will not send its message. Once the handshake frequency is received and understood by the panel, the panel sends its message. If there is an error in the transmission (the receiver does not receive a “valid” message), the kissoff frequency is not given by the Central Station receiver.

The panel makes a total of eight attempts to the primary telephone number and eight attempts to the secondary telephone number (if programmed) to get a valid message through. If the panel is not successful after its numerous attempts, the keypad displays COMM. FAILURE (on alpha keypads) or FC (on fixed-word keypads).

Report Code Formats

The following chart indicates the types of (handshake/kissoff) frequencies that the panel supports and the different formats that can be sent with each.

FORMAT	HANDSHAKE	TRANSMITS DATA	KISSOFF	TRANSMIT TIME
Low Speed 3+1, 4+1, 4+2	1400 Hz	1900Hz (10PPS)	1400 Hz	Under 15 secs (Standard report)
Sescoa/Rad 3+1, 4+1, 4+2	2300 Hz	1900Hz (20PPS)	2300 Hz	Under 10 secs (Standard report)
Express 4+2	1400–2300 Hz	DTMF (10 cps)	1400 Hz	Under 3 secs
Contact ID	1400–2300 Hz	DTMF (10 cps)	1400 Hz	Under 3 secs

The following table describes each format in greater detail.

FORMAT TYPE	DESCRIPTION
3+1 and 4+1 Standard Formats	Comprises a 3- (or 4-) digit subscriber number and a single-digit report code (e.g., Alarm, Trouble, Restore, Open, Close, etc).
3+1 and 4+1 Expanded Formats	Comprises a 3- (or 4-) digit subscriber number and a two-digit report code. The first digit is displayed on the first line. On the second line, it is repeated 3 (or 4) times and is followed by the second digit. This is the “expanded” digit.
4+2 Format	Comprises a 4-digit subscriber number and 2-digit report code.
ADEMCO Contact ID Reporting Format	Comprises a 4 or 10-digit subscriber number (depending on the format selected), 1-digit event qualifier (“new” or “restore”), 3-digit event code, and 3-digit zone number, user number, or system status number (see the following page).

The following table lists codes for reports sent in different formats:

Type of Report	Code for 3+1/4+1 Code for Standard	Code for 3+1/4+1 Expanded	4+2
Alarm	SSS(S) A SSSS AZ	SSS(S) A AAA(A) Z	
Trouble	SSS(S) T SSSS Tt	SSS(S) T TTT(T) t	
Bypass	SSS(S) B SSSS Bb	SSS(S) B BBB(B) b	
AC Loss	SSS(S) E SSSS EA _C	SSS(S) E EEE(E) A _C	
Low Batt	SSS(S) L SSSS LL _B	SSS(S) L LLL(L) L _B	
Open	SSS(S) O SSSS OU	SSS(S) O OOO(O) U	
Close	SSS(S) C SSSS CU	SSS(S) C CCC(C) U	
Test	SSS(S) G SSSS Gg	SSS(S) G GGG(G)g	
Restore	SSS(S) R SSSS RZ	SSS(S) R RRR(R) Z	
Alarm			
AC Restore	SSS(S) R _A SSSSR _A A _c	SSS(S) R _A R _A R _A R _A (R _A)A _c	
LoBat Res.	SSS(S) R _L SSSS R _L L _B	SSS(S) R _L R _L R _L R _L (R _L)L _B	
Trouble Res.	SSS(S) R _T SSSS R _T t	SSS(S) R _T R _T R _T R _T (R _T)t	
Bypass Res.	SSS(S) R _B SSSS R _B b	SSS(S) R _B R _B R _B R _B (R _B)b	

Where:

SSS or SSSS = Subscriber ID	C = Close Code–1st Digit
A = Alarm Code–1st digit	U = User Number (in hex)
Z = Typically Zone Number*–2nd digit	Gg = Test Code (1st & 2nd digits)
Tt = Trouble Code (1st & 2nd digits)	R = Restore Code (Alarm)
Bb = Bypass Code (1st & 2nd digits)	R _T t = Restore Code (Trbl) 1st & 2nd
EA _C = AC Loss Code (1st & 2nd digits)	R _B b = Restore Code (Byps) 1st & 2nd
LL _B = Low Battery Code (1st & 2nd digits)	R _A A _C = Restore Code (AC) 1st & 2nd digits
O = Open Code–1st Digit	R _L L _B = Restore Code (Bat) 1st & 2nd

*Zone numbers for: * & #, or B = 99 1 + *, or A = 95 Duress = 92
 3 + #, or C = 96 Tamper = 9

Ademco Contact ID®

The Ademco Contact ID® Reporting Format comprises the following:

- 4-digit or 10-digit subscriber number (depending on format selected).
- 1-digit event qualifier (“new” or “restore”).
- 3-digit event code.
- 3-digit zone number, user number, or system status number (see the following page).

Ademco Contact ID® Reporting takes the following format: CCCC(CCCCC) Q EEE GG ZZZ
where:

CCCC(CCCCC) = Customer (subscriber) ID

Q = Event qualifier, where:

E = new event , and R = restore

EEE = Event code (3 hexadecimal digits)

Note: For a complete list of event codes, refer to the central office receiver manual.

GG = Partition number (always sent as “01” for this control; system messages show “00.”

ZZZ = Zone/contact ID number reporting the alarm, or user number for open/close reports. System status messages (AC Loss, Walk Test, etc.) contain zeroes in the ZZZ location.

TABLE OF CONTACT ID EVENT CODES

Code	Definition
110	Fire Alarm
121	Duress
122	Alarm, 24-hour Silent
123	Alarm, 24-hour Audible
131	Alarm, Perimeter
132	Alarm, Interior
134	Alarm, Entry/Exit
135	Alarm, Day/Night
143	Alarm, Expansion Module
145	ECP Module cover tamper
146	Silent Burglary
150	Alarm, 24-Hour Auxiliary/Monitor zone
162	Carbon Monoxide
301	AC Power
302	Low System Battery/Battery Test Fail
305	System Reset (Log only)
309	Battery Test Failure
321	Bell/Siren Trouble
333	Trouble, Expansion Mod. Supervision
341	Trouble, ECP Cover Tamper
344	RF Receiver Jam
351	Telco Line Fault
353	Long Range Radio Trouble
373	Fire Loop Trouble
374	Exit Error Alarm
380	Global Trouble, Trouble Day/Night

Code	Definition
381	RF Supervision Trouble
382	Supervision Auxiliary Wire Zone
383	RF Sensor Tamper
384	RF Sensor Low-battery
393	Clean Me
401	Disarmed, Armed AWAY, Armed MAXIMUM
403	Schedule Arm/Disarm AWAY
406	Cancel by User
407	Remote Arm/Disarm (Downloading)
408	Quick Arm AWAY
409	Keypad Arm/Disarm AWAY
441	Disarmed/Armed STAY/INSTANT, Quick-Arm STAY/INSTANT
442	Keypad Arm/Disarm STAY
570	Bypass
601	Manually Triggered Dialer Test
602	Periodic Test
606	AAV to Follow
607	Walk Test Entered/Exited
623	Event Log 80% Full
625	Real-Time Clock was Changed (log only)
627	Program Mode Entry (log only)
628	Program Mode Exit (log only)
642	Latch Key (log only)
750 - 789	Reserved for Configurable Zone Type report codes (check with central station when using these codes)

User Security Codes

The system supports up to 16 security codes, which can each be assigned one of 4 authority levels. The authority level determines the functions each code can perform as follows:

Authority Levels (authority levels can be assigned to users 3-16 only; users 1 and 2 cannot be changed)

Level	User No.	Functions
Installer	01	(default=4112) perform all security functions except can disarm only if used to arm; can enter program mode; can change System Master code; cannot assign any other user codes
System Master	02	(default 1234) only one system master code per system; can perform all security functions, add/delete users, change system master code, view event log, set system clock, program keypad macro, program scheduled events, activate output devices (triggers/relays)
0-User	03-16	perform security functions (arm, disarm, etc.) only; cannot add/delete users, view event log, set system clock or program scheduled events
1-Arm Only	see "user"	arm system only
2-Guest	see "user"	can disarm the system only if it was used to arm the system
3-Duress	see "user"	performs security functions, but also silently sends a duress message to the central station; reports as duress code user number.

Refer to the user guide for procedures on adding/deleting security codes and changing attributes. The following is a brief description of how to add user codes.

Adding a User Code: Master code + [8] + 2-digit user no. + user's code

Deleting a User Code: Master code + [8] + 2-digit user no. + [#] [0]

Assigning Attributes: Master code + [8] + 2-digit user no. + [#] [attribute no.] + value

Attributes: Values

1 = Authority Level 0-3 (see Authority Level table above)

2 = Access Group 0-8 (0 = not assigned to a group)

3 = Not Used

4 = RF Zone No.; assigns user number to button type zone (keyfob) for arm/disarm.
(keyfob must be enrolled in system first; see *Wireless Key Templates* section)

5 = Open/Close Paging; 1 for yes, 0 for no

Keypad Functions

The following is a brief list of system commands. For detailed information, see the User's Manual.

Voice Keypads

The FA560VKP Voice Keypad provides the following features:

- Message Center, which lets the user record and playback one message.
- Voice Status, which can announce system status by using the STATUS key.
- Voice Chime, which can alert users to the opening of doors/windows while the system is disarmed.

Refer to the User Guide for specific procedures for activating and using these features.

Setting the Real-Time Clock

1. +[#] + [6] [3]
 (Security Code)

Alpha Display:

```
DISARMED
READY TO ARM
```

2. Press [*] when the time/date is displayed.
 A cursor appears under the first digit of the hour.
To move cursor ahead, press []. To go back, press [#].*

```
TIME/DATE SAT
04:04PM 10/17/00
```

Current time display

- Enter the 2-digit hour and 2-digit minute setting.
- Press [1] for PM or [2] for AM.
- Enter the last two digits of the current year.
- Enter the 2-digit month and 2-digit day setting.

```
TIME/DATE SAT
04:04P2000/10/17
```

Time/date editing display

3. To exit, press [*] when cursor is at the last digit, or wait 10 seconds.

Keypad Commands

Function	Description
Silence alarms	Pressing any key will silence the keypad sounder for 10 seconds. Disarming the system will silence both keypad and external sounders.
Quick Arm	If enabled (field *21), you can press [#] in place of the system's security code, plus the desired arming key (Away, Stay, Instant, Maximum)
Single-Button arming	If programmed (*57 Function Key menu mode), lettered keys A-D can be used for arming, using options 3-AWAY, 4-STAY, 5-NIGHT-STAY, or 6-Step-Arming. If used, no security code is required to arm the system.
Alarm Memory	When the system is disarmed, any zones that were in an alarm condition during the armed period will be displayed. To clear this display, simply repeat the disarm sequence (enter the security code and press the OFF key) again.
Arming Away	Enter code + AWAY [2] or simply press appropriate lettered key on the keypads (see "Single-Button Arming" above).
Arming Stay	Enter code + STAY [3] or simply press appropriate key on the keypads (see "Single-Button Arming" above).
Arming Night-Stay	Enter code + STAY [3] + STAY [3] or simply press appropriate key on the keypads (see "Single-Button Arming" above).
Arming Instant	Enter code + INSTANT [7].
Arming Maximum	Enter code + MAXIMUM [4] or simply press appropriate lettered key on the keypads (see "Single-Button Arming" above).
Disarming	Enter code + OFF [1]. If entry delay or an alarm is active, you do not need to press OFF.
Bypassing Zones	Enter code + BYPASS [6] + zone number(s).
Forced (Quick) Bypass	To automatically bypass all faulted zones, use the "Quick Bypass" method. Enter code + BYPASS + [#], then wait for all open zones to be displayed. Arm when display indicates "ZONE BYPASSED" and "READY TO ARM".
Chime Mode	Enter code + CHIME [9]. To turn chime off, enter code + CHIME again.
Activate Output Devices	If relay outputs are used, two keypad entries available to the user are included. If programmed, these entries can be used to manually activate or deactivate the device(s) for starting or stopping some action, such as turning lights on or off, etc. These keypad entries are: [Security Code] + # + 7 + [2-digit Device #] activates (starts) that device. [Security Code] + # + 8 + [2-digit Device #] deactivates (stops) that device.

SUMMARY OF ARMING MODES

Arming Mode	Features for Each Arming Mode			
	Exit Delay	Entry Delay	Perimeter Armed	Interior Armed
AWAY	Yes	Yes	Yes	Yes
STAY	Yes	Yes	Yes	No
NIGHT-STAY	Yes	Yes	Yes	only those zones listed in Night-Stay zone list
INSTANT	Yes	No	Yes	No
MAXIMUM	Yes	No	Yes	Yes

Panic Keys

There are three Panic keys (A, B, and C) that, if programmed, can be used to manually initiate alarms and send a report to the central station by pressing and holding the appropriate key for at least 2 seconds. Each key can be programmed for 24-hour Silent, 24-hour Audible, Fire, or Personal Emergency responses. The Panic keys are identified by the system as follows:

Keys	Displayed as Zone
[A] (*/1)	95
[B] (*/#)	99
[C] (3/#)	96

IMPORTANT: For a Silent panic function (if programmed) to be of practical value, you must program a report code for the zone and the system must be connected to a central station.

Various System Trouble Displays

Alpha Display	Fixed Disp.	Meaning
CANCELED ALARM	CA	will appear if an exit or interior zone contained a fault during closing at the time the Exit Delay ended (e.g., exit door left open), but the system was disarmed during the Entry Delay time. The alarm sounder and keypad sound continuously, but stop when the system is disarmed. No message will be transmitted to the central station.
EXIT ALARM	EA	will appear when the Exit Delay ends if an exit or interior zone contained a fault during closing. The alarm sounder and keypad sound continuously until the system is disarmed (or timeout occurs). An "Exit Alarm" message is sent to the central station. Also results if an alarm from an exit or interior zone occurs within 2 minutes after the end of an Exit Delay.
CHECK	CHECK	indicates that a problem exists with the displayed zone(s) and requires attention. Note: The control will sense a high resistance in the loops on hardwired zones 2–8 and display "CHECK" and the affected zone number when the system is in the disarmed mode. It will not be possible to arm the system as long as this condition exists (unless this zone is bypassed). If the system is in the armed mode when the high resistance condition occurs, this display will not appear, but will do so as soon as the system is disarmed. Check the sensor or loop wiring for the displayed zone.
ALARM 1xx FAULT 1xx CHECK 1xx	1xx 1xx 1xx 91	indicates that communication between control and a zone expander or wireless receiver is interrupted, where "xx" is the device address. Check the wiring and DIP switch settings on the units. If field *199 is set to "1," all ECP module problems are displayed as "91." If there are wireless sensors in the system, the Check condition may also be caused by some change in the environment that prevents the receiver from receiving signals from a particular sensor.
SYSTEM LO BAT	BAT	with no zone number indicates that the system's main standby battery is weak.
LO BAT	BAT	with a zone number and a once-per-minute beeping at the keypad indicates that a low-battery condition exists in the wireless sensor displayed (zone "00" indicates a wireless keypad). If the battery is not replaced within 30 days, a "CHECK" display may occur. NOTE: Some wireless sensors use a non-replaceable long-life battery which requires replacement of the entire unit at the end of battery life (e.g., 5802, 5802CP).
Busy-Standby	dl	If this remains displayed for more than 1 minute, the system is disabled.
Modem Comm	CC	The system is in communication with the central station for change of function or status verification.
no display	no display	Power Failure If there is no keypad display at all and the LEDs are unlit, operating power (AC and battery) for the system has stopped and the system is inoperative. If the message "AC LOSS" (Alpha display keypads) or "NO AC" (Fixed-Word display keypads) is displayed, the keypad is operating on battery power only. If the battery standby capacity is used up during a prolonged AC power outage, the control's power will shut down to minimize deep discharge of the battery.
Comm. Failure	FC	A communication failure has occurred.
Open Circuit	OC	The keypad is not receiving signals from the control and sees an open circuit.
Long Rng Trbl	bF	Backup LRR communication failure.
Bell Failure	70	Bell supervision failure.
RCVR Jam	90	RF jam detected.
KEYPAD LOW BAT	00 BAT	Wireless keypad low battery
Phone Okay	Cd	The dialer test has been successful (CID code 601).
Dialer Off	dO	The dialer is disabled.
Test in Progress	dd	Walk test mode is active(CID code 607).
Upload Completed	dC	The upload or download session was completed.
Upload Failed	dF	The upload or download session failed before completion.

SECTION 7

Testing the System

About Test Procedures

After the installation is complete, you should perform the following tests:

- System Test: Checks that all zones have been installed properly and the system properly responds to faults.
- Dialer Test: Checks that the phone connection to the central station is working properly.
- Go/No Go Test: Checks that transmissions can be received from transmitters. Should be performed before permanently mounting transmitters.
- RF Sniffer Mode: Checks that RF transmitter serial numbers have been properly entered into the system.
- Battery Tests: Automatic battery tests are performed by the system. See Automatic Battery Test paragraph for details.

System Test

With the system in the disarmed state, check that all zones are intact (not faulted). Doors and windows with contacts should be closed, PIRs should be covered (use a cloth to mask them temporarily if necessary). If a “NOT READY” message is displayed, press [*] to display the faulted zone(s). Restore faulted zone(s) if necessary, so that the “READY” message is displayed.

1. Enter Installer Code + 5 [TEST], then press “0” at the prompt to start Walk Test mode.

1=DIAL, 0=WALK

(no special display on Fixed-Word Display Keypads; displays “DISARMED READY TO ARM”)

The following will be displayed:

TEST IN PROGRESS

(“dd” displayed on Fixed-Word Display Keypads)

A Contact ID report will also be sent (code 607)

2. Upon entering the system test mode, the outside sounder should sound for 1 second. If the backup battery is discharged or missing, the sounder may not turn on and a “LOW BATTERY” report will be transmitted with a “TEST” report. The keypad will beep once per minute as a reminder that the system is in the Test mode.
NOTE: Wireless motion detectors (Passive Infrared units) will send signals out only if they have been inactive for 3 minutes (conserves battery life).
3. Test all sensors using the procedure described in the User’s Guide “Testing the System” section and/or the each device’s instructions.
4. After checking sensors, turn off the test mode by entering installer code + OFF.

NOTE: Test mode automatically ends after 4 hours. During the final 5 minutes (after 3 hours 55 minutes of Test mode), the keypad emits a double-beep every 30 seconds to alert that the end of Test mode is nearing.

Checking Transmitter Enrollment (Sniffer Mode)

Use this mode to verify that all transmitters have been properly programmed.

1. Press [Installer code] + [#] + 3.
The keypads will display all zone numbers of wireless units programmed into the system. Fault each transmitter in turn, causing each one to send a signal. As the system receives a signal from each transmitter, the zone number of that transmitter disappears from the display.
NOTE: If the communicator is in the process of sending a report to the central station, the system will not go into the Sniffer mode. If so, wait a few minutes, and try again.
2. After all transmitters have been checked, exit the sniffer mode by: [**Installer code**] + **OFF**.
IMPORTANT: Sniffer mode does not automatically expire. You must manually exit Sniffer mode (by entering [**Installer code**] + **OFF**) to return to normal operation.

- NOTES:**
- All BR type units must physically be activated to clear the display.
 - When **one** button of a transmitter (RF, UR, or BR) is activated, all zones assigned to other buttons on that transmitter are cleared. This also applies to 5816 and 5817 transmitters, which have multiple loops (zones).
 - Any transmitter that is not “enrolled” will not turn off its zone number.

Go/No Go Test Mode

The Go/No Go Test verifies adequate RF signal strength from the proposed transmitter location, and allow you to reorient or relocate transmitters if necessary, before mounting the transmitters permanently. This mode is similar to the Transmitter Test mode, except that the wireless receiver gain is reduced. This will enable you to make sure that the RF signal from each transmitter is received with sufficient signal amplitude when the system is in the normal operating mode.

1. Enter **[Installer code] + [#] + 4**.
2. After you have placed transmitters in their desired locations and the approximate length of wire to be run to sensors is connected to the transmitter's screw terminals (if used), fault each transmitter. Do not conduct this test with your hand wrapped around the transmitter.
 - a. The keypad beeps three times to indicate signal reception and displays the unit's zone number.
 - b. If the keypad does not beep, you should reorient or move the transmitter to another location. Usually a few inches in either direction is all that is required.
4. If each transmitter produces the proper keypad response when it is faulted, you can then permanently mount each of the transmitters according to the instructions provided with them.
5. Exit the Go/No Go Test mode by entering: **[Installer code] + OFF**.

Dialer Communication Test and Periodic Test Reports

The following steps can be followed to manually test communication to the central station.

1. Enter Installer Code + 5 [TEST], then press “1” at the prompt to start the Dialer Test.

1=DIAL, 0=WALK

(no special display on Fixed-Word Display Keypads; displays “DISARMED READY TO ARM”)

The following will be displayed (accompanied by 2 beeps) if test is successful:

PHONE OKAY

(“Cd” displayed on Fixed-Word Display Keypads)
A Contact ID report will also be sent (code 601)

If the dialer test is unsuccessful, the following is displayed:

COMM FAILURE

(“FC” displayed on Fixed-Word Display Keypads)

2. Enter installer code + OFF to clear the display and exit.

Automatic Periodic Test Report

The system can be set to automatically send test reports (enabled in field *64; Contact ID code 602) at specified intervals.

Frequency of the reports is set in Scheduling mode (event 11) or by the following key commands:

installer code + [#] + 0 + 0 = test report sent every 24 hours

installer code + [#] + 0 + 1 = test report sent once per week

installer code + [#] + 0 + 2 = test report sent every 28 days

Each mode sets schedule 2 to the stated repeat option; first test report sent 12 hours after command. To ensure that test reports are sent at the times expected, set the Real-Time Clock to the proper time **before** entering the test report schedule command.

Automatic Standby Battery Tests

1. An automatic test is conducted every 3 minutes to ensure that a standby battery is present and properly connected. If a battery is not present or is not properly connected, a “LOW BATTERY” message is displayed and, if so programmed, will be reported to the central station.
2. A battery capacity test is automatically conducted for 2 minutes every 4 hours, beginning 4 hours after exiting the Programming mode or after powering up the system. In addition, entry into the Test mode will also cause a battery capacity test to be initiated. If the battery cannot sustain a load, a “Low Battery” message is displayed and, if so programmed, will be reported to the central station.

Specifications & Accessories

SECURITY CONTROL

Physical: 12-1/2" W x 14-1/2" H x 3" D (318mm x 368mm x 76mm)

Electrical:

VOLTAGE INPUT: 16.5VAC from plug-in 25VA transformer, Ademco No. 1321 (in U.S.A.)

RECHARGEABLE BACKUP BATTERY: 12VDC, 4AH (sealed lead acid type).

Charging Voltage: 13.8VDC.

ALARM SOUNDER: 12V, 2.0 Amp output can drive 12V BELLS or can drive one or two 702 (series connected) self-contained 20-watt sirens.

Do **not** connect two 702s in parallel.

AUXILIARY POWER OUTPUT: 12VDC, 600mA max.

NOTE: For UL installations, Alarm Sounder plus Auxiliary Power currents should not exceed 600mA total.

FUSE: Battery (3A) No. 90-12

Maximum Zone Resistance: Zones 1-8 = 300 ohms excluding EOLR standard zones

Communication:

FORMAT SUPPORTED:

ADEMCO Express: 10 characters/sec, DTMF (TouchTone) Data Tones, 1400/2300Hz ACK, 1400Hz KISSOFF.

ADEMCO Low Speed: 10 pulses/sec, 1900Hz Data Tone, 1400Hz ACK/KISSOFF.

Radionics/SESCOA: 20 pulses/sec, 1800Hz Data Tone, 2300Hz ACK/KISSOFF.

Can report 0-9, B-F

Ademco Contact ID 10 characters/sec., DTMF (TouchTone) Data Tones, 1400/2300Hz ACK, 1400Hz KISSOFF.

LINE SEIZE: Double Pole

RINGER EQUIVALENCE: 0.1B

FCC REGISTRATION No.: 5GBUSA-44003-AL-E

COMPATIBLE DEVICES

Keypads: FA215KP, FA260KP, FA260RF, FA560KP, FA560VKP

Wireless Receivers: 5881L/5882L: accepts up to 8 transmitters

5881M/5882M: accepts up to 16 transmitters

5800TM Transmitter Module (used with 5827BD Wireless 2-Way Keypad)

5883 Transceiver: accepts up to system maximum transmitters

FA260RF Keypad/Transceiver: accepts up to system maximum transmitters

Relay Module: 4204 RELAY MODULE

Phone Modules: FA4285 PHONE MODULE

FA4286VIP PHONE MODULE

Long Range Radio 7835C/7845C

Sounders: Ademco AB-12M 10" Motorized Bell & Box

Ademco 1011BE12M 10" Motorized Bell & Box

Ademco 702 Outdoor Siren

Ademco 719 2-Channel Siren

Ademco 747 Indoor Siren

Ademco 747UL Indoor Siren

Ademco 744 Siren Driver

Ademco 745X3 Voice Siren Driver

Ademco 705-820, 5-inch Round Speaker

Ademco 713 Speaker

System Sensor PA400B (beige)/; PA400R (red) Indoor Piezo Sounder

5800 Series Transmitter Input Loop Identification

All of the transmitters illustrated below have one or more unique factory assigned input (loop) ID codes. Each of the input loops requires its own programming zone (e.g., a 5804's four inputs require four programming zones).

NOTE: For information on any transmitter not shown, refer to the instructions accompanying that transmitter for details regarding loop numbers, etc.

UL NOTE: The following transmitters are not intended for use in UL installations:
 5802MN, 5802MN2, 5804, 5804BD, 5814, 5816TEMP, 5819, 5819WHS & BRS, and 5850.

Diagram details:
 - 5801: Four pushbuttons labeled LOOP 1, LOOP 2, LOOP 3, LOOP 4. Enrollment: "ENROLL AS 'UR' OR 'RF'".
 - 5802MN: Single pushbutton labeled LOOP 1. Enrollment: "ENROLL AS 'UR' OR 'RF'".
 - 5816MN: Reed switch labeled LOOP 2 (REED) and terminals labeled LOOP 1 (TERMINALS). Enrollment: "ENROLL AS 'RF'".
 - 5817: Reed switch labeled LOOP 1 (PRIMARY), terminals labeled LOOP 2 (AUX. CENTER) and LOOP 3 (AUX. RIGHT). Enrollment: "ENROLL AS 'RF'".
 - 5804: Four pushbuttons labeled LOOP 1, LOOP 2, LOOP 3, LOOP 4. Enrollment: "ENROLL AS 'BR'".
 - 5804BD: Four pushbuttons labeled LOOP 1, LOOP 2, LOOP 3, LOOP 4. Enrollment: "ENROLL AS 'BR'". Includes "SET HOUSE CODE" button.
 - 5819: Reed switch labeled LOOP 2 (REED) and terminals labeled LOOP 3 (TERMINALS) and LOOP 1 (TERMINALS). Enrollment: "ENROLL AS 'RF'".
 - 5819S (WHS & BRS): Reed switch labeled LOOP 2 (REED) and terminals labeled LOOP 3 (TERMINALS) and LOOP 1 (INTERNAL SHOCK SENSOR). Enrollment: "ENROLL AS 'RF'".
 - 5827: "SET HOUSE CODE" button.
 - 5827BD: "SET HOUSE CODE" button.
 - 5809: Reed switch labeled LOOP 1. Enrollment: "ENROLL AS 'RF'".
 - 5808: Reed switch labeled LOOP 1. Enrollment: "ENROLL AS 'RF'".
 - 5816: Reed switch labeled LOOP 2 (REED) and terminals labeled LOOP 1 (TERMINALS). Enrollment: "ENROLL AS 'RF'".
 - 5850 (GBD): "SET HOUSE CODE" button.
 - 5890: Motion sensor labeled LOOP 1 (MOTION). Enrollment: "ENROLL AS 'RF'".

Compatible 5800 Series Transmitters Table

Model	Product	Input Type	Description
5801	Wireless Panic Transmitter	UR or RF	<ul style="list-style-type: none"> Four pushbuttons, each with a unique input (loop) code. Programmable responses (e.g., Panic, Arm, Disarm, etc.)
5802	Pendant (Personal Emergency Transmitter)	BR Only	<ul style="list-style-type: none"> Has single pushbutton. Usually programmed for response type of 24-Hr audible or 24-Hr Silent (other zone responses are possible).
5802CP	Belt Clip (Personal Emergency)	BR Only	Same as 5802.
5802MN	Miniature (Personal Emergency Trans.)	UR or RF	Same as 5802.
5804	Wireless Key Transmitter	BR Only	<ul style="list-style-type: none"> Has four pushbuttons, each with a unique input (loop) code. Programmable responses (e.g., Arm, Disarm, etc.)
5804BD	Bi-Directional Wireless Key	BR	<ul style="list-style-type: none"> House ID must be set. Requires 5800TM Transmitter Module. Can indicate system status via its 2 LEDs and built-in sounder. Has four pushbuttons, each with a unique input (loop) code. Operates the system similarly to wired keypads.
5806 5807 5808	Wireless Photoelectric Smoke Detectors	RF	One-piece smoke detectors with a built-in transmitter.
5809	Heat Detector	RF	One-piece rate-of-rise heat detector with a built-in transmitter.
5816 5816MN	Door/Window Transmitters	RF	Has two unique input (loop) codes: one for a wired closed circuit contact loop; the other for its built-in reed switch (used with a magnet).
5816TEMP	Low-Temp. Sensor	RF	Transmits a fault condition when temperature drops below 45°F.

Compatible 5800 Series Transmitters Table (continued)

Model	Product	Input Type	Description
5817	Multi-Point Universal Transmitter	RF	Has three unique input (loop) codes: one for a "Primary" contact loop with programmable options; the others for two "auxiliary" closed circuit contact loops.
5818	Recessed Transmitter	RF	<ul style="list-style-type: none"> • Reed switch magnetic contact sensor; easily hidden in the frame and edge of a door or window. • Has a single unique input (loop) code.
5819	Shock Processor Transmitter	RF	<ul style="list-style-type: none"> • Connects to externally mounted inertia-type shock detector (not supplied). • Has built-in tampered cover switch. • Has 3 unique input (loop) codes: <i>Loop 1:</i> Terminals for a wired, N.C. sensor loop. <i>Loop 2:</i> For a closed circuit contact loop using the built-in reed switch in conjunction with a magnet. <i>Loop 3:</i> Terminals for a wired, closed circuit contact loop.
5819WHS 5819BRS	Shock Processor Transmitter	RF	<ul style="list-style-type: none"> • Has built-in shock sensor. • Has built-in tampered cover switch. • Has 3 unique input (loop) codes: <i>Loop 1:</i> Built-in shock sensor loop wired to TB1 (normally closed). <i>Loop 2:</i> For a closed circuit contact loop using the built-in reed switch in conjunction with a magnet. <i>Loop 3:</i> Externally wired, closed circuit loop connected to TB2.
5827	Wireless Keypad	Uses House ID only	<ul style="list-style-type: none"> • Can be used to turn the burglary protection on and off. • Features the same built-in panic functions as wired keypads. • The keypad is identified as zone "00" on wired keypads when it transmits with a low battery.
5827BD	Wireless Two-Way Keypad	Uses House ID only	<ul style="list-style-type: none"> • Requires 5800TM Transmitter Module. • Operates the system similarly to wired keypads, including panics. • Can indicate system status via its 3 LEDs and sounder. • Includes 3 panic keys.
5849	Glassbreak Detector	RF	<ul style="list-style-type: none"> • House ID must also be set. • Requires both sound and shock of breaking glass to cause alarm to be transmitted.
5890	PR Detector	RF	Dual-element passive infrared detector/transmitter with built-in selectable pulse count. <i>Note:</i> There is a 3-minute lockout between fault transmissions to conserve battery life.
5899	Magnets		Package of 4 magnets for use with 5816 and 5817 transmitters.

Regulatory Agency Statements

RADIO FREQUENCY EMISSIONS

Federal Communications Commission (FCC) Part 15

This device complies with part 15 of the FCC rules. Operation is subject to the following two conditions: (1) This device may not cause harmful interference, and (2) this device must accept any interference received, including interference that may cause undesired operation.

Industry Canada

This Class B digital apparatus complies with Canadian ICES-003.

Cet Appareil numérique de la classe B est conforme à la norme NMB-003 du Canada.

TELEPHONE/MODEM INTERFACE

FCC Part 68

This equipment complies with Part 68 of the FCC rules. On the front cover of this equipment is a label that contains the FCC registration number and Ringer Equivalence Number (REN). You must provide this information to the telephone company when requested.

This equipment uses the following USOC jack: RJ31X

This equipment may not be used on telephone-company-provided coin service. Connection to party lines is subject to state tariffs. This equipment is hearing-aid compatible.

Industry Canada

NOTICE: The Industry Canada Label identifies certified equipment. This certification means that the equipment meets telecommunications network protective, operational and safety requirements as prescribed in the appropriate Terminal Equipment Technical Requirements document(s). The Department does not guarantee the equipment will operate to the user's satisfaction.

Before installing this equipment, users should ensure that it is permissible to be connected to the facilities of the local telecommunications company. The equipment must also be installed using an acceptable method of connection. The customer should be aware that compliance with the above conditions may not prevent degradation of service in some situations.

Repairs to certified equipment should be coordinated by a representative designated by the supplier. Any repairs or alterations made by the user to this equipment, or equipment malfunctions, may give the telecommunications company to request the user to disconnect the equipment.

Users should ensure for their own protection that the electrical ground connections of the power utility, telephone lines and internal metallic water pipe system, if present, are connected together. This precaution may be particularly important in rural areas.

Caution: Users should not attempt to make such connections themselves but should contact appropriate electric inspection authority, or electrician, as appropriate.

Ringer Equivalence Number Notice:

The **Ringer Equivalence Number (REN)** assigned to each terminal device provides an indication of the maximum number of terminals allowed to be connected to a telephone interface. The termination on an interface may consist of any combination of devices subject only to the requirement that the sum of the Ringer Equivalence Numbers of all the devices does not exceed 5.

Industrie Canada

AVIS: L'étiquette d'Industrie Canada identifie le matériel homologué. Cette étiquette certifie que le matériel est conforme aux normes de protection, d'exploitation et de sécurité des réseaux de télécommunications, comme le prescrivent les documents concernant les exigences techniques relatives au matériel terminal. Le Ministère n'assure toutefois pas que le matériel fonctionnera à la satisfaction de l'utilisateur.

Avant d'installer ce matériel, l'utilisateur doit s'assurer qu'il est permis de le raccorder aux installations de l'entreprise locale de télécommunication. Le matériel doit également être installé en suivant une méthode acceptée du raccordement. L'abonné ne doit pas oublier qu'il est possible que la conformité aux conditions énoncées ci-dessus n'empêche pas la dégradation du service dans certaines situations.

Les réparations de matériel homologué doivent être coordonnées par un représentant désigné par le fournisseur. L'entreprise de télécommunications peut demander à l'utilisateur de débrancher un appareil à la suite de réparations ou de modifications effectuées par l'utilisateur ou à cause de mauvais fonctionnement.

Pour sa propre protection, l'utilisateur doit s'assurer que tous les fils de mise à la terre de la source d'énergie électrique, de lignes téléphoniques et des canalisations d'eau métalliques, s'il y en a, sont raccordés ensemble. Cette précaution est particulièrement importante dans les régions rurales.

Avertissement : L'utilisateur ne doit pas tenter de faire ces raccordements lui-même; il doit avoir recours à un service d'inspection des installations électriques, ou à un électricien, selon le cas.

AVIS : L'indice d'équivalence de la sonnerie (IES) assigné à chaque dispositif terminal indique le nombre maximal de terminaux qui peuvent être raccordés à une interface. La terminaison d'une interface téléphonique peut consister en une combinaison de quelques dispositifs, à la seule condition que la somme d'indices d'équivalence de la sonnerie de tous les dispositifs n'excède pas 5.

UL NOTICES

1. Entry Delay No. 1 and No. 2 (fields *35, *36) cannot be greater than 30 seconds for UL Residential Burglar Alarm installations, and entry delay plus dial delay should not exceed 1 minute. For UL Commercial Burglar Alarm installations, total entry delay may not exceed 45 seconds.
2. For UL Commercial Burglar Alarm (Grade AA) and UL Residential Burglar Alarm installations with line security, total exit delay time must not exceed 60 seconds. For UL Burglar Alarm installations without line security (Grade A), total exit delay time must not exceed 120 seconds.
3. The maximum number of reports per armed period (field *93) must be set to "0" (unlimited) for UL installations.
4. Periodic testing (see scheduling mode) must be at least every 24 hours.
5. Alarm Sounder plus Auxiliary Power currents must not exceed 600mA total for UL installations (Aux power 500mA max.).
6. Downloading is not permissible for UL installations.
7. If used, the audible alarm device(s) must be placed where it/they can be heard by all users.
8. For UL commercial burglar alarm installations the control unit must be protected from unauthorized access. The tamper switch installed to protect the control unit enclosure door is suitable for this purpose.
9. Remote downloading without an alarm company technician on-site is not a UL Listed feature.
10. Auto-disarming is not a UL Listed feature.

Limitations and Warranty

WARNING

THE LIMITATIONS OF THIS ALARM SYSTEM

While this System is an advanced design security system, it does not offer guaranteed protection against burglary, fire or other emergency. Any alarm system, whether commercial or residential, is subject to compromise or failure to warn for a variety of reasons. For example:

- Intruders may gain access through unprotected openings or have the technical sophistication to bypass an alarm sensor or disconnect an alarm warning device.
- Intrusion detectors (e.g., passive infrared detectors), smoke detectors, and many other sensing devices will not work without power. Battery-operated devices will not work without batteries, with dead batteries, or if the batteries are not put in properly. Devices powered solely by AC will not work if their AC power supply is cut off for any reason, however briefly.
- Signals sent by wireless transmitters may be blocked or reflected by metal before they reach the alarm receiver. Even if the signal path has been recently checked during a weekly test, blockage can occur if a metal object is moved into the path.
- A user may not be able to reach a panic or emergency button quickly enough.
- While smoke detectors have played a key role in reducing residential fire deaths in the United States, they may not activate or provide early warning for a variety of reasons in as many as 35% of all fires, according to data published by the Federal Emergency Management Agency. Some of the reasons smoke detectors used in conjunction with this System may not work are as follows. Smoke detectors may have been improperly installed and positioned. Smoke detectors may not sense fires that start where smoke cannot reach the detectors, such as in chimneys, in walls, or roofs, or on the other side of closed doors. Smoke detectors also may not sense a fire on another level of a residence or building. A second floor detector, for example, may not sense a first floor or basement fire. Finally, smoke detectors have sensing limitations. No smoke detector can sense every kind of fire every time. In general, detectors may not always warn about fires caused by carelessness and safety hazards like smoking in bed, violent explosions, escaping gas, improper storage of flammable materials, overloaded electrical circuits, children playing with matches, or arson. Depending on the nature of the fire and/or location of the smoke detectors, the detector, even if it operates as anticipated, may not provide sufficient warning to allow all occupants to escape in time to prevent injury or death.
- Passive Infrared Motion Detectors can only detect intrusion within the designed ranges as diagrammed in their installation manual. Passive Infrared Detectors do not provide volumetric area protection. They do create multiple beams of protection, and intrusion can only be detected in unobstructed areas covered by those beams. They cannot detect motion or intrusion that takes place behind walls, ceilings, floors, closed doors, glass partitions, glass doors, or windows. Mechanical tampering, masking, painting or spraying of any material on the mirrors, windows or any part of the optical system can reduce their detection ability. Passive Infrared Detectors sense changes in temperature; however, as the ambient temperature of the protected area approaches the temperature range of 90° to 105°F (32° to 40°C), the detection performance can decrease.
- Alarm warning devices such as sirens, bells or horns may not alert people or wake up sleepers if they are located on the other side of closed or partly open doors. If warning devices are located on a different level of the residence from the bedrooms, then they are less likely to waken or alert people inside the bedrooms. Even persons who are awake may not hear the warning if the alarm is muffled by noise from a stereo, radio, air conditioner or other appliance, or by passing traffic. Finally, alarm warning devices, however loud, may not warn hearing-impaired people.
- Telephone lines needed to transmit alarm signals from a premises to a central monitoring station may be out of service or temporarily out of service. Telephone lines are also subject to compromise by sophisticated intruders.
- Even if the system responds to the emergency as intended, however, occupants may have insufficient time to protect themselves from the emergency situation. In the case of a monitored alarm system, authorities may not respond appropriately.
- This equipment, like other electrical devices, is subject to component failure. Even though this equipment is designed to last as long as 10 years, the electronic components could fail at any time.

(Continued)

WARNING
THE LIMITATIONS OF THIS ALARM SYSTEM
(Continued)

The most common cause of an alarm system not functioning when an intrusion or fire occurs is inadequate maintenance. This alarm system should be tested weekly to make sure all sensors and transmitters are working properly. The security keypad (and remote keypad) should be tested as well.

Wireless transmitters (used in some systems) are designed to provide long battery life under normal operating conditions. Longevity of batteries may be as much as 4 to 7 years, depending on the environment, usage, and the specific wireless device being used. External factors such as humidity, high or low temperatures, as well as large swings in temperature, may all reduce the actual battery life in a given installation. This wireless system, however, can identify a true low-battery situation, thus allowing time to arrange a change of battery to maintain protection for that given point within the system.

Installing an alarm system may make the owner eligible for a lower insurance rate, but an alarm system is not a substitute for insurance. Homeowners, property owners and renters should continue to act prudently in protecting themselves and continue to insure their lives and property.

We continue to develop new and improved protection devices. Users of alarm systems owe it to themselves and their loved ones to learn about these developments.

– INDEX –

- 1321 1-1, 2-4
 - 24-Hour Audible Alarm 3-3
 - 24-Hour Silent Alarm 3-3
 - 3+1 and 4+1 Standard Formats... 6-1
 - 4204 .. 1-2, 2-5, 2-6, 2-9, 3-1, 5-6, 8-1
 - 4229 2-6, 3-1
 - FA4285 Phone Module 1-1, 2-12, 5-11
 - FA4286 Phone Module 1-1, 2-12, 5-11
 - 4-Wire Smoke Detectors 2-6
 - 5800 Series Transmitters 2-8, 8-2, 8-3
 - 5800TM 2-7, 2-8, 8-1, 8-2, 8-3
 - 5801 2-8, 8-2
 - 5802 2-8, 6-6, 8-2
 - 5802CP 2-8, 6-6, 8-2
 - 5804 wireless key 5-4
 - 5804BD wireless key 5-4
 - 5827 2-8, 4-1, 8-3
 - 5827BD 2-7, 2-8, 4-1, 8-1, 8-2, 8-3
 - 5881 1-1, 2-5, 2-7
 - 7720PLUS or 7820 1-1
 - 9-pin connector 2-8
- A**
- AAV Connections 2-12
 - AC Power Supply 1-1
 - AC Transformer 2-4
 - AD12612 2-3
 - Alarm Output 1-1, 2-4, 2-5
 - Alarm Sounder Timeout 4-2
 - Alpha Descriptor 5-1, 5-3, 5-12
 - Alpha Keypads 3-5
 - Alpha Programming 3-1
 - Alpha Vocabulary List 5-11
 - Arming Away 6-5
 - Arming Instant 6-5
 - Arming Modes 6-5
 - Arming Stay 6-5
 - Audio Alarm Verification (AAV) .. 2-10
 - Authority Levels 6-4
 - Auto-STAY Arming 4-6
 - Auxiliary Output 2-5
- B**
- Backup Battery 1-1
 - Battery Life 2-8
 - Battery Tests 7-1, 7-2
 - Bell Supervision 2-4
 - Bell Supervision Jumper 2-4
 - Bypassing Zones 6-5
- C**
- Cabinet 2-1
 - California State Fire Marshall 2-5
 - Caller ID Unit 2-10
 - Cancel Report Code 4-5
 - Character List 5-12
 - Charging Voltage 8-1
 - Chime Mode 4-10, 6-5
 - Communication 5-10, 6-1, 7-2, 8-1
 - Configurable Zone Type Options. 4-9
 - Configurable Zone Type Programming Fields 4-9
 - Contact ID Reporting 8-1
 - Custom Words 5-11, 5-12, 13
- D**
- Data Field Programming Procedures 3-5
 - Defining Output Functions 5-7
 - Descriptor Programming 5-11
 - device address 2-3, 2-9, 3-1, 3-6, 4-1, 4-11, 5-6, 6-6
 - Device number 5-1, 5-2, 5-3, 5-4, 5-7, 5-9
 - DIP Switches 2-8
 - Disarming 5-8, 6-5
- E**
- Enrolling 2-8, 5-1
 - entering serial number 5-4
 - Entry Delay 3-3, 4-9, 6-5, 6-6
 - Entry Delay 02 4-2
 - Entry/Exit Burglary 3-3
 - Event Logging 1-1, 4-7
 - Exit Delay 4-2, 4-7, 4-9, 6-5, 6-6
 - Exit Error Alarm 6-6
 - Exit Error Report Code 4-4
 - Expert Programming Mode .. 5-3, 5-5
- F**
- Factory Defaults 3-5
 - Fast Busy Signal 2-11
 - Fault Delay Time 4-6
 - Function Key Programming 1-2, 3-1, 5-10
 - Function Keys 3-2, 5-10
 - Fuse 8-1
- G**
- Go/No Go Test Mode 7-2
- H**
- Handshake 6-1
 - hardwired zones 1-1, 6-6
 - HAYES Modem 1-1
 - House ID 2-8, 4-1, 8-2, 8-3
- I**
- IBM Personal Computer 3-1
 - Ideal Model 61–035 2-5
 - Input Device Type 5-4, 8-2, 8-3
 - Installer Code 3-5, 4-8, 7-1, 7-2
 - Interior Follower 3-3, 5-1, 5-8
 - Interior w/Delay 3-3, 5-1, 5-8
- K**
- keypad addresses 2-3, 3-1
 - Keypad Programming Fields 4-11
 - Keyswitch 2-8, 2-9, 3-4, 5-1
 - Kissoff 5-8, 6-1
- L**
- Lock 2-1
 - Long Range Radio 1-1, 2-11, 4-3, 4-4, 3, 8-1
 - Low Battery Message 7-2
- M**
- macros 1-1
 - model 112 2-8
 - Modem 3-1, 6-6
 - momentary switch 2-8
- N**
- No Alarm Response 3-4, 5-8
 - Normally Closed Zones 2-6
 - Normally Open Zones 2-6
- O**
- On-Board Triggers 2-10, 2-12
 - Output Device Mapping 3-1, 5-6
 - Output Devices 3-2, 5-6, 6-5
 - Output Functions 5-6
 - Output relays 1-1
 - Output To Long Range Radio 4-1
- P**
- Pager Format 4-8
 - Pager Programming 3-2, 4-8
 - Paging 4-7
 - Panic Keys 6-5
 - Perimeter Burglary 3-3
 - Phone Line 2-10
 - Phone Module 1-1, 2-3, 2-5, 2-10, 2-11, 2-12, 4-1, 4-7, 5-11, 5-12, 8-1
 - Power Failure 5-8, 6-6
 - power supply 2-3, 2-4, 2-5, 10-2
 - Primary Phone No. 4-4
- Q**
- Quick Arm Enable 3-1
- R**
- Receiver and Transmitters 3-2
 - Relay Modules 1-2, 2-9
 - Relay Programming 3-1
 - Remote Keypads 1-1
 - Report Code 4-4, 4-5, 4-6, 4-7, 4-9, 5-2, 5-4, 6-1
 - Report Code Formats 6-1
 - Reports In Armed Period 4-7
 - response time 4-6, 5-1
 - RF Interference 2-7
 - RF jam detection 1-1
 - RF Receiver 2-1, 2-2, 2-3, 2-5, 2-7, 3
 - RJ31X Jack 2-10, 2-11
- S**
- Schedules 5-14
 - Security Codes 1-1, 6-4
 - Silent Burglary 3-4, 5-1, 5-8, 3
 - Silent Panic 6-5
 - Smoke Detectors 8-2
 - Sniffer Mode 5-3, 7-1
 - sounder connections 2-4
 - Supervised Fire 3-3
 - Supplementary Power 2-3
 - Swinger Suppression 4-7
 - System Communication 4-9, 5-2, 6-1
 - System Operation 5-4, 5-5, 5-8, 5-14
 - System Status Report Codes 4-4
 - System Test 7-1

T

Tamper Switch2-8, 2-9, 9-2
Telco Line 2-11, 3
Test Mode 7-1, 7-2
Test Restore Report Code..... 4-6
Transmitter Battery Life 2-8
Transmitter Input Types 5-2
Trouble by Day/ 3-3
Trouble Displays..... 6-4, 6-6

V

Vocabulary List.....5-11

W

Wireless Key Templates.....5-4
Wiring Length/Gauge Chart2-3
Wiring Run Chart2-3
Word String5-12
Worksheet2-5

Z

Zone Lists 3-1, 5-9
Zone Programming Procedure 5-1
Zone Types..... 3-3, 5-1, 5-4, 5-8

LIMITED WARRANTY

Pittway Corporation, and its divisions, subsidiaries and affiliates ("Seller"), 165 Eileen Way, Syosset, New York 11791, warrants its First Alert products to be in conformance with its own plans and specifications and to be free from defects in materials and workmanship under normal use and service for 36 months from the date stamp control on the product or, for products not having a date stamp, for 30 months from date of original purchase unless the installation instructions or catalog sets forth a shorter period, in which case the shorter period shall apply. Seller's obligation shall be limited to repairing or replacing, at its option, free of charge for materials or labor, any product which is proved not in compliance with Seller's specifications or proves defective in materials or workmanship under normal use and service. Seller shall have no obligation under this Limited Warranty or otherwise if the product is altered or improperly repaired or serviced by anyone other than First Alert Professional factory service. For warranty service, return product transportation prepaid, to: First Alert Professional Factory Service, 165 Eileen Way, Syosset, New York 11791.

THERE ARE NO WARRANTIES, EXPRESS OR IMPLIED, OF MERCHANTABILITY, OR FITNESS FOR A PARTICULAR PURPOSE OR OTHERWISE, WHICH EXTEND BEYOND THE DESCRIPTION ON THE FACE HEREOF. IN NO CASE SHALL SELLER BE LIABLE TO ANYONE FOR ANY CONSEQUENTIAL OR INCIDENTAL DAMAGES FOR BREACH OF THIS OR ANY OTHER WARRANTY, EXPRESS OR IMPLIED, OR UPON ANY OTHER BASIS OF LIABILITY WHATSOEVER, EVEN IF THE LOSS OR DAMAGE IS CAUSED BY THE SELLER'S OWN NEGLIGENCE OR FAULT.

Seller does not represent that the products it sells may not be compromised or circumvented; that the products will prevent any personal injury or property loss by burglary, robbery, fire or otherwise; or that the products will in all cases provide adequate warning or protection. Customer understands that a properly installed and maintained alarm may only reduce the risk of a burglary, robbery, fire or other events occurring without providing an alarm, but it is not insurance or a guarantee that such will not occur or that there will be no personal injury or property loss as a result. CONSEQUENTLY, SELLER SHALL HAVE NO LIABILITY FOR ANY PERSONAL INJURY, PROPERTY DAMAGE OR OTHER LOSS BASED ON A CLAIM THE PRODUCT FAILED TO GIVE WARNING. HOWEVER, IF SELLER IS HELD LIABLE, WHETHER DIRECTLY OR INDIRECTLY, FOR ANY LOSS OR DAMAGE ARISING UNDER THIS LIMITED WARRANTY OR OTHERWISE, REGARDLESS OF CAUSE OR ORIGIN, SELLER'S MAXIMUM LIABILITY SHALL NOT IN ANY CASE EXCEED THE PURCHASE PRICE OF THE PRODUCT, WHICH SHALL BE THE COMPLETE AND EXCLUSIVE REMEDY AGAINST SELLER. This warranty replaces any previous warranties and is the only warranty made by Seller on this product. No increase or alteration, written or verbal, of the obligations of this Limited Warranty is authorized



149 Eileen Way, Syosset, NY 11791
Copyright © 2002 Pittway Corporation



K0735-1 8/02